DEVELOPMENT OF EXPERIMENTAL EQUIPMENT FOR VEGETABLE OIL FUEL RESEARCH

Aivars Birkavs, Ilmars Dukulis

Latvia University of Agriculture

aivars.birkavs@llu.lv; ilmars.dukulis@llu.lv

Abstract

The European Parliament and Council Directive 2003/30/EK 'On the promotion of the use of biofuels and other renewable fuels for transport' determines that pure or straight vegetable oil, produced from oil plants by pressing, extracting or comparable procedures, crude or refined but chemically unmodified, compatible with common engines, and corresponding to emission requirements, is also considered as biofuel. The biggest problems imposed by these conditions are directly associated with the carrying-out of the emission requirements, because when using vegetable oil as a fuel, usually increases the composition of the solid particles and nitrogen oxides in exhaust gases, that not only adversely affect the environment, but also is a serious threat to human health, and as a result trying to save the world from the global warming, human health continues to deteriorate. It is therefore necessary to carry out studies and find solutions to reduce harmful emissions from diesel engines when using vegetable oil fuel. For more qualitative and effective research on vegetable oil fuel emissions, the equipment for vegetable oil fuel testing has been developed. This equipment allows fast checking of theoretically proposed hypotheses and detailed calculations for vegetable oil fuel combustion processes and objective data acquisition. The equipment consists of the classic diesel engine adapted for work with vegetable oil and is equipped with several high-precision devices to get and store the measuring data. During pilot tests the optimal measuring modes (engine rotation frequencies, number and duration of repetitions) for further research are estimated.

Key words: straight vegetable oil (SVO), two-tank system, exhaust emissions.

Introduction

As technologies evolve, vegetable oil in pure form or as a blend with fossil diesel is increasingly used as a diesel engine fuel. Based on the results of previous studies, it may be concluded that the vegetable oil which corresponds to EU standards can be used in diesel engines for a long time, and its application does not cause the engine or the system damage. Investigations on vegetable oil fuel emissions composition prove that the content of the toxic substances in the exhaust gases, similar to biodiesel, is reduced in comparison with the fossil diesel, and the quantity of the certain toxic emissions is even less than using biodiesel. However, the vegetable oil as fuel does not display very significant reduction of the harmful emissions in the exhaust gases. Particularly, the level of the mechanical particles and nitrogen oxide either increases or slightly decreases depending on the type of the engine, method of conversion, and fuel injection in a diesel engine cylinder (Dukulis et al., 2010).

The exhaust gases contain such harmful substances as nitrogen oxides, carbon oxides, hydrocarbons, carbon monoxide, soot, particulate matter, and sulphur dioxide. The most harmful exhaust gases arise from the engine warming up and idling.

In the previous studies performed at the Scientific Laboratory of Biofuels (Latvia University of Agriculture) generally were used vehicles as a whole (cars) that had been tested on power bench (Dukulis et al., 2009, 2009a, 2009b, 2010). Investigating such vehicles, the original car fuel tank was used also for vegetable oil, and thereby it was difficult to carry out experiments on various vegetable oil blends. Therefore, only 'pure' fuels, i.e., fossil diesel, biodiesel and rapeseed oil were used in these experiments.

Pilot tests on different fuel blends were labour and time consuming, because a large amount of fuel was needed for testing, and it was practically impossible to empty fuel tank when changing the fuel. So, when carrying out experiments on a car with diesel engine running on vegetable oil, it is impossible to draw general conclusions about the change tendencies of the exhaust gases, using a variety of fuel or fuel blends, because the switching from one fuel to another creates complications, for example, it is not possible to determine the time taken for the new fuel to fill the entire fuel system, as well as it's difficult to determine the fuel consumption in different engine operating modes.

Another problem is that the vegetable oil usually is not compatible with the modern exhaust gas purification systems, such as particulate filters or SCR (*Selective Catalytic Reduction*) system. Using vegetable oil as a fuel, it is impossible to make full use of the vehicle potential to reduce the harmful emissions (Alternative Fuels, 2007).

Taking into account these arguments and in order to successfully carry out experiments for the purpose of determining the exhaust gas and fuel consumption changes of the vegetable oil and blends, the following tasks were set for this investigation:

- ◆ to build a diesel engine test bench;
- ◆ to equip diesel engine with the 'two-tank system' to run on vegetable oil;
- ◆ to provide a free exhaust system, i.e., not to use catalytic neutralisation and exhaust gas recirculation;
- ◆ to supplement diesel control measuring equipment with the engine rotation frequency meter;
- ◆ to work out and connect the computerized fuel consumption measuring system;

- ◆ to estimate the optimal measuring modes (speed, time, number of repetitions) for further studies.

Materials and Methods

The equipment for determination of vegetable oil fuel emissions from diesel engines and for measuring of fuel consumption operated in the laboratory, where temperature of the surrounding air was 20 – 22 °C. The exhaust gas absorption system was added to the engine exhaust system to prevent the harmful effect of the emissions during the experiment.

The equipment consisted of *Opel 16 DA* diesel engine, *Elsbett* ‘two-tank system’ to run engine on vegetable oil, and *KERN 440-49A* weighing system. To determine the composition of the exhaust gases during the experiment, *AVL SESAM FTIR* multicomponent exhaust gas measurement system was additionally connected. For the engine rotation frequency control, the stroboscope *DG 85* was used, receiving impulses from the first cylinder high-pressure pipe.

Opel 16 DA diesel engine is single line 4/OHC engine having a capacity of 1598 cm³, compression ratio – 23, and the power of 40 kW. Diesel fuel system is powered by fuel pump *Bosch VE 4/9R215* providing a nozzle opening pressure to 135 bar.

To run the diesel engine on vegetable oil, *Elsbett* ‘two-tank system’ was installed and consisted of the following components:

- ◆ additional 20 litre fuel tank;
- ◆ additional fuel filter;
- ◆ electric fuel pumps;
- ◆ heat exchanger for fuel heating;
- ◆ thermo switch;
- ◆ electromagnetic valve;
- ◆ back-pressure valve;
- ◆ control unit;
- ◆ switches and sockets;
- ◆ fuel and cooling liquid pipelines.

‘Two-tank system’ included the following subsystems:

- ◆ fuel supply and heating system (Figure 1);
- ◆ electronic control system (Figure 2).

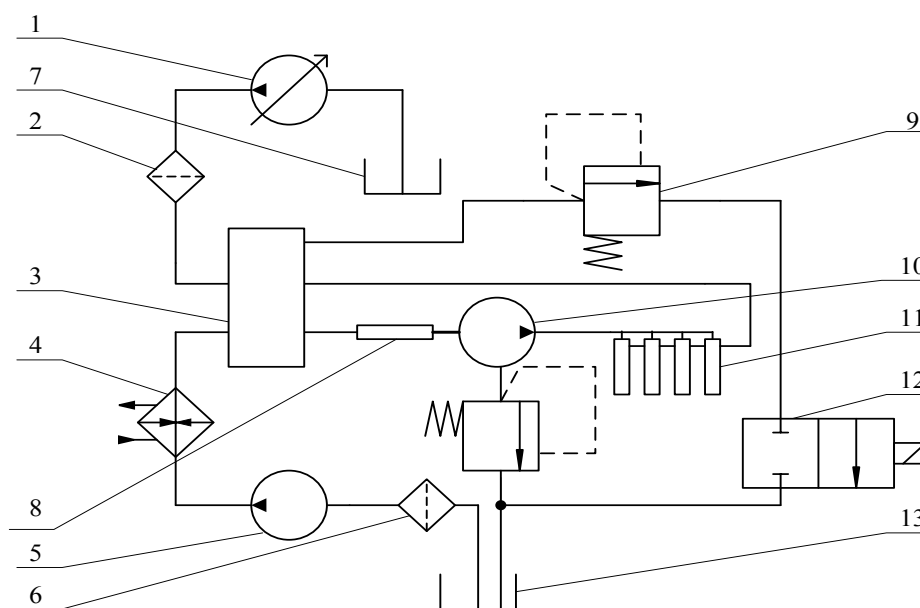

Figure 1. Fuel supply and heating system: 1, 5 – electric pumps; 2 – fossil fuel filter; 3 – distributor; 4 – heat exchanger; 6 – vegetable oil filter; 7 – fossil fuel tank; 8 – transparent glass tube; 9 – one-way valve; 10 – high-pressure fuel pump; 11 – nozzles; 12 – electromagnetic valve; 13 – vegetable oil tank.

The fuel supply and heating system was based on fuel pumps which were intended for the vegetable oil and fossil diesel fuel supply to a diesel engine high-pressure pump, as well as for providing the low-pressure system with the required fuel pressure. To guarantee the vegetable oil with the necessary viscosity, served a heat exchanger that provided heat transfer between the cooling system and the vegetable oil supply system. An additional fuel tank served for the fossil diesel fuel storage, required for the diesel engine warm-up process, as well as before fuel supply system to be filled. Electromagnetic valve provided vegetable oil flow to the vegetable oil fuel tank. The valve

could be controlled also manually.

The electronic control system was based on the control unit which task was to ensure a proper function of all components and to maintain stable running of the engine with fossil diesel and vegetable oil or blends. One of the most important elements of the electrical system was thermo switch that allowed switching the diesel engine running on vegetable oil only after the engine has reached 70 – 80 °C temperature. If the engine temperature dropped below 70 °C, the system automatically switched to powering by fossil diesel fuel.

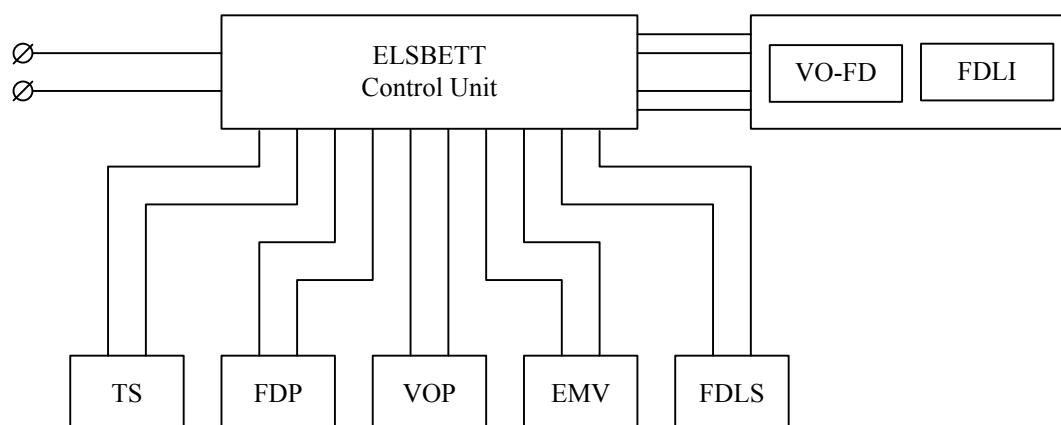

Figure 2. Simplified electronic control system: TS – thermo switch; FDP – fossil diesel fuel pump; VOP – vegetable oil pump; EMV – electromagnetic valve; FDLS – fossil diesel fuel level sensor; VO-FD – vegetable oil to fossil diesel fuel switch; FDLI – fossil diesel fuel level indicator.

The fuel consumption measurement system was developed on the basis of *KERN 440-49A* electronic weighing system which provides measurements with an accuracy of 0.1 g at intervals of 1 second. Weighing system management and data registration is computer controlled.

Before starting the measurements, diesel exhaust pipe was connected to the *AVL SESAM FTIR* multicomponent exhaust gas measurement system, and the following operations were done:

- ◆ connect the exhaust gas extraction system;
- ◆ connect the engine revolution frequency meter (stroboscope);
- ◆ inspect engine technical condition, paying particular attention to engine oil and coolant levels;
- ◆ turn on electricity supply;
- ◆ connect and adjust electronic weighing system;
- ◆ place the fuel storage container on the weighing platform and fix the fuel hoses so that they do not touch the container edges;
- ◆ fill the fuel container with tested fuel;
- ◆ check whether diesel engine is switched to powering by fossil diesel fuel;
- ◆ start the diesel engine;
- ◆ check the stroboscope operation;
- ◆ warm the engine up to 70 – 80 °C;
- ◆ switch the engine to work on the tested fuel.

To make it easier to determine what fuel is in the fuel

supply system, a transparent glass tube was built in the system. If it is not possible to visually determine what fuel there is in the supply system, starting another fuel testing it is necessary to undertake the following actions:

- ◆ pour out the previous test fuel from container;
- ◆ fill the new test fuel into a fuel container;
- ◆ remove the back-flow pipe from the fuel container and place in a measuring cup;
- ◆ check whether diesel engine is switched to work with vegetable oil and start the engine;
- ◆ ensure that the system works with the new fuel;
- ◆ stop the engine and put the back-flow pipe into the fuel container;
- ◆ adjust electronic weighing system;
- ◆ start the engine and the measurement.

The results of the fuel consumption and exhaust gas content were fixed by the computerized measurement systems, and then processed with a spreadsheet application tools.

Results and Discussion

The investigation resulted in a fully functioning diesel engine test bench, equipped with a ‘two-tank system’ to run on rapeseed oil, supplemented by the engine rotation frequency meter and connected to a computerized fuel consumption measurement system (Figure 3).

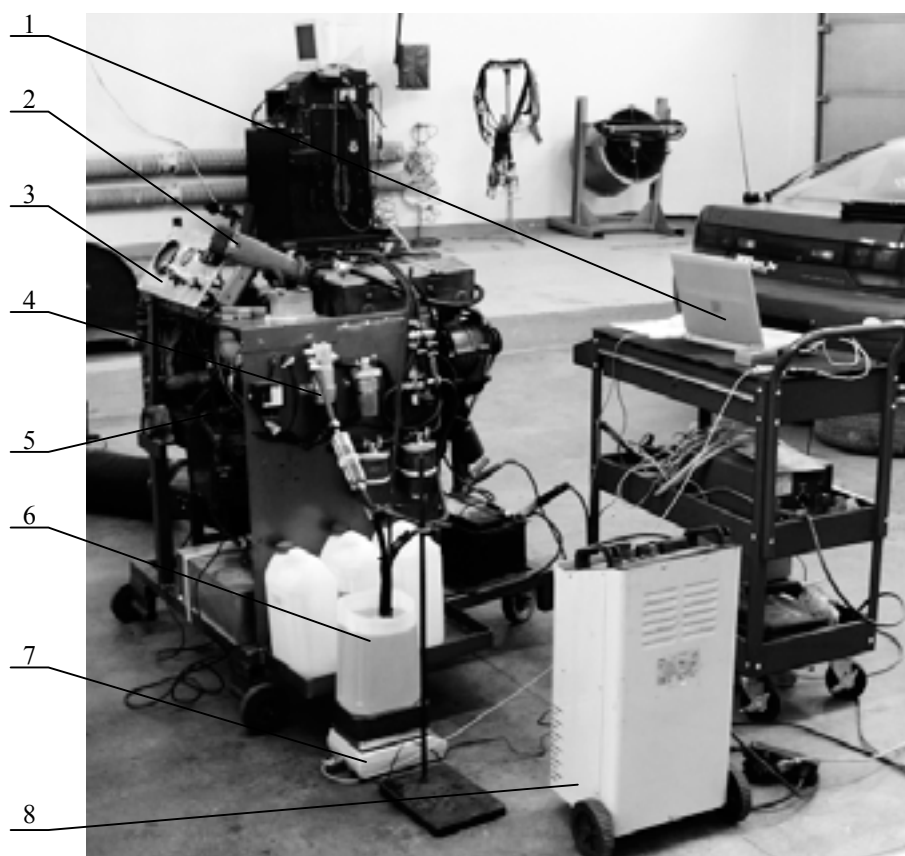

Figure 3. Diesel engine test bench: 1 – PC with special *KERN 440-49A* software; 2 – stroboscope *DG 85*; 3 – *ELSBETT* control unit; 4 – ‘two-tank system’ components; 5 – *Opel 16 DA* diesel engine; 6 – container with tested fuel; 7 – *KERN 440-49A* weighing system; 8 – additional electric power source.

To get reliable and verifiable results of different fuel or fuel blends experiments, the testing modes were determined, as well as the fuel system volume, timing for each test, and the number of repetitions.

Engine rotation frequency increase contributes to oxides (NO_x , NO and CO) increase, while the engine working at nominal speed significantly reduces the carbon monoxide content of exhaust gases (Smigins, 2010). Consequently, three speed regimes were selected to determine the emission content changes – 850 to 900 rpm, 1500 rpm and 2500 rpm.

Fuel system volume was determined experimentally, using two fuels with different colours. The fuel system was switched to a new fuel, but the back-flow fuel pipe was placed into a separate measuring cup. By visual observation (transparent glass tube in the system) filling up of the fuel supply system with the new fuel was stated. According to the measurement it was established that the fuel supply system volume was 1.5 litres. It means that this volume has to flow out of the system before the experiments with the new fuel can be started.

To determine the optimal duration for each experiment and the number of repetitions, pilot tests were carried out. Taking into account the fuel consumption absolute values for each test mode, at the lowest engine speeds, i.e., 850 rpm, the duration for each experiment initially was chosen longer (5 minutes) than at higher speeds, i.e., 1500 and 2500 rpm (3 minutes).

Whereas the *KERN 440-49A* weights can give a signal to a computerized data recording system only when the weights are at equilibrium, but flowing out fuel from the container does not always provide such a balance then simple reading of the values of fuel mass at the beginning and the end of the experiment by default can cause errors in research results. Therefore fuel consumption graphs for each test mode were created, but the regression function and R^2 value characterizing the closeness between experimental data and the regression function were determined for the first minute data, the first two minutes data, the first three minutes data, and so on.

As an example Figure 4 shows such pilot test fuel consumption graphs at 2500 rpm.

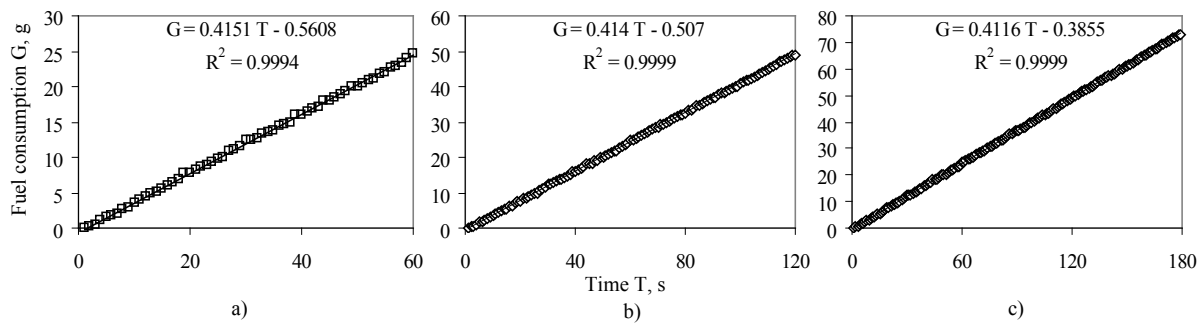

Figure 4. Pilot test fuel consumption graphs at 2500 rpm: a – 1st minute of test; b – 1st and 2nd minute of test; c – 1st, 2nd and 3rd minute of test.

As can be seen from the graphs, after the second measuring minute the R² value stopped to increase, so at 2500 rpm for further research the duration for each

measurement can be estimated to 2 minutes, but the regression function can be used for calculating the hourly fuel consumption in this mode, for example:

$$G_{hour} = 0.414 \cdot T_{hour} - 0.507 = 0.414 \cdot 3600 - 0.507 = 1489.9 \text{ g h}^{-1}$$

By analogy, it was determined that at the lowest engine speeds, i.e., 850 – 900 rpm, the optimal duration of each measurement was 3 minutes, but at 1500 rpm – 2 minutes.

The correlation between the measurement results of individual repetitions was calculated. As an example Table 1 shows the fuel consumption data fragment from three repetitions (tests) at 850 rpm.

The correlation between the measurement results

Table 1

Correlation calculations between the fuel consumption measurement results of individual repetitions

Time, s	Fuel consumption, g		
	Test No 1	Test No 2	Test No 3
1	0	0	0
2	0.3	0.3	0.6
3	0.6	0.3	0.6
4	0.6	0.9	0.6
5	0.9	0.9	0.9
6	0.9	0.9	0.9
7	1.2	1.4	0.9
8	1.2	1.4	1.2
9	1.4	1.7	1.4
10	1.7	1.7	1.4
...
...
...
178	30.2	29.5	28.4
179	30.4	29.9	28.7
180	30.4	29.9	29.2
Correlation			
Test No 1	N/A	0.999005	0.999246
Test No 2	0.999005	N/A	0.999524
Test No 3	0.999246	0.999524	N/A

As can be seen from the data of Table 1, correlation between the individual data points of three measurement repetitions was above 99.9%. These results qualify as a high rating, therefore more than three repetitions at each of the modes are not needed.

sufficiently close dispersion of exhaust gas components, that, taking into account the fact that the exhaust gases are not ‘very homogeneous substances’, is common in experiments of many researchers. As an example Table 2 shows the exhaust emission measurement data from three repetitions (tests) at 850 rpm comparing the components most often analyzed in studies around the world.

Finally, it was verified if at a chosen number of repetitions and duration of each experiment there is

Table 2

Exhaust emission measurement results of individual repetitions

Test No	Content in exhaust emissions, ppm					
	NO _x	Mechanical particles	SO ₂	Unburned hydrocarbons	CO ₂	CO
1	167.72	5.50	0.28	141.36	23700.37	354.46
2	169.80	5.47	0.29	144.17	23422.70	349.72
3	168.38	5.27	0.29	141.01	23763.61	354.03
Average	168.64	5.41	0.28	142.18	23628.89	352.74
Difference, (Max/Min) %	1.25%	4.24%	2.57%	2.24%	1.46%	1.36%

The differences between individual repetition maximum and minimum values did not exceed 5%, which for exhaust emission studies was assessed as a very good result, therefore all selected modes were considered optimal for future studies.

Conclusions

1. Developed diesel engine test bench effectively allows carrying out research on vegetable oil fuel and fossil fuel blend combustion process.
2. The main advantage of the installed 'two-tank system' is that experiments with vegetable oil fuel can be started or stopped at any engine temperatures, without any engine or fuel system damage.
3. Free exhaust system enables to determine the emission content changes directly after fuel combustion process.
4. The use of the stroboscope for rotation frequency measurement is the most accurate from analogue systems because it gets impulse from high pressure fuel pipe at the moment of the fuel injection.
5. Computerized fuel consumption measurement system, worked out on the basis of KERN 440-49A weighing system, can be used for high-accuracy dynamic measurements on the fuel consumption changes.
6. During pilot tests the optimal measuring modes (engine rotation frequencies, number and duration of repetitions) for further studies were estimated. At the lowest engine speeds, i.e., 850 – 900 rpm, the optimal duration of each measurement was 3 minutes, but at 1500 rpm and 2500 rpm – 2 minutes. Three repetitions at each of the modes are enough to get valid results.

Acknowledgements

The authors gratefully acknowledge the funding from Latvian Council of Science (project No. 09.1602 'Investigations of biofuel and biomass technologies') and the European Union and European Structural Fund (grant No. 2009/0180/1DP/1.1.2.1.2/09/IPIA/VIAA/017 'Support for Doctoral Study Programs').

References

1. Alternative Fuels (2007) Vol. 1. Teaching and Learning Material. Supported within the 6th EU Framework Programme, 108 p. Available at: <http://www.infolizer.com/5eltisa1or7g/Alternative-fuels.html>, 15 March 2011.
2. Dukulis I., Birkavs A., Birzietis G., Pirs V. (2009) Adapting of Automobile VW Golf for Using Pure Rape Oil As a Fuel. *Proceedings of the 8th International Scientific Conference 'Engineering for Rural Development'*. Latvia University of Agriculture, Jelgava, pp. 141-147.
3. Dukulis I., Pirs V., Jesko Z., Birkavs A., Birzietis G. (2009a) Development of Methodics for Testing Automobiles Operating on Biofuels. *Proceedings of the 8th International Scientific Conference 'Engineering for Rural Development'*. Latvia University of Agriculture, Jelgava, pp. 148-155.
4. Dukulis I., Pirs V., Jesko Z., Birkavs A., Birzietis G. (2009b) Testing of Automobile VW Golf Operating on Three Different Fuels. *Proceedings of the 8th International Scientific Conference 'Engineering for Rural Development'*. Latvia University of Agriculture, Jelgava, pp. 7-13.
5. Dukulis I., Birzietis G., Birkavs A., Pirs V., Jesko Z. (2010) Exhaust Emissions from the Vehicles Operating on Rapeseed Oil Fuel. *Agronomy Research*, Volume 8, Special Issue 1. Estonian University of Life Sciences, Tartu, pp. 39-46.
6. Smigins R. (2010) Impact of Biodiesel on Working Parameters of the Engine. Promotion Paper Summary for Acquaring the Doctor's Degree in Engineering Sciences. Latvia University of Agriculture, Jelgava, 54 p.