

RESEARCH IN INFLUENCE OF ENGINE AIR FILTER REPLACEMENT PERIODICITY

Maris Gailis, Vilnis Pirs
Latvia University of Agriculture
maris@electromobile.lv

Abstract. The study evaluates current periodicity of engine air filter replacement to determine the influence of this operation on some vehicle performance parameters. The experience of usage, costs of exploitation and technical condition of the vehicle are connected with a technically and economically based system of technical servicing. Periodicity of motor air filter replacement, declared by the automobile manufacturer Renault ranges from 30 000 km to 120 000 km, depending on the model and engine type. According to the same recommendations, periodicity must be reduced by a half, if conditions of use include dusty roads and exploitation of the vehicle in urban conditions. The aim of the research is to evaluate the criteria, according to which actual replacement of motor air filters was performed and to measure the influence of air filters with different levels of use on the engine performance. To reach the goal, air filter cartridges from 100 vehicles of the same model and type, which were used in Latvia were collected. The influence of air filter clogging on several vehicle exploitation parameters, such as engine power and fuel consumption was analyzed. The value of maximum permissible pressure difference before and after the air filter was determined. Air filters, collected from vehicles, were tested on the test bench for the value of air pressure difference. The results obtained with all the samples have been presented and critically examined.

Keywords: automobile technical servicing, engine air filter, engine air cleaner, restriction of air flow.

Introduction

All internal combustion engines require supply of air. This air must be clean, dry, fresh and cool. Unfiltered air can rapidly wear out an engine. In a short period of time the engine can lose compression and power, start to emit heavy smoke. The tests by major diesel engine manufacturers have shown that as little as two tablespoons of dirt can wear out the engine within very short time [1]. On paved roads, the dust content of the air averages $1 \text{ mg}\cdot\text{m}^{-3}$, however, on unpaved roads and on construction sites the dust content can be as high as $40 \text{ mg}\cdot\text{m}^{-3}$. This means that – depending on the roads and operating conditions – a medium-sized engine can draw in up to 50 g of dust over 1000 km [2]. The size of dust particles varies from 0.01 mm till 2 mm. The average efficiency of air filters is 99.8 % for passenger vehicles and 99.95 for commercial vehicles [3]. Efficiency remains constant throughout the engine speed range [1]. As the air filter builds a dust film, the holes in the media become smaller, and the filter becomes more efficient at trapping dirt. As the filter traps dirt, it is more difficult for the air to pass through the filter, and restriction increases in the air induction system. Most diesel engines operate at a maximum 4.98 to 6.22 kPa vacuum under full load. Gasoline engine calibrations can vary depending on the engine size and air cleaner design and most gasoline engine powered automobiles have 4.98 kPa maximum pressure drop at fully open throttle. Air filter restriction usually remains low through most of the filter service life, and then increases rapidly at the end. [4]. The value of air filter restriction is the key parameter to be used considering filter replacement.

1. Air induction and filtration systems

Automotive engine air filters have been subject of evolution for decades. The coarse metal mesh and oil bath systems were introduced since early 1920's. The oil wetted batt type engine air cleaners were introduced in the 1950's. Significant improvements have been made in the design, development and use of engine air cleaner design, development and use for automotive applications. Superior filtration performance is necessary for engine air cleaners to protect engines and electronic flow sensors. The air cleaner of a modern vehicle usually consists of a plastic casing and replaceable filter cartridge.

A wide variety of filter media can be configured to design engine air cleaners with high performance levels. Typical media used in the engine air filter design are the following:

- cellulose fiber paper media with phenolic resin binder system;
- cellulose/synthetic paper blend paper media;
- synthetic fiber paper media;
- multi-layered cellulose/synthetic felt media;

- dual stage filters using reticulated foams or felts as prefilters [5].

Engine air cleaners are designed to effectively remove airborne contaminants in order to protect the engine throughout its service life. The engine requires that the ingested air meets a minimum level of cleanliness to reduce the engine wear, improve the engine efficiency and protect the electronic sensors [7].

The function and design of intake air filters must address the following:

- engine durability;
- filtration;
- flow management;
- water/snow ingestion management;
- pressure or head loss constraints;
- overall noise, vibration, and temperature standards;
- competitive pricing requirements;
- service requirements;
- packaging;
- styling/appearance;
- emissions [6; 7].

2. Engine air filter service life

Estimating the service life for a particular engine size or vehicle can be complex. However, understanding the service life requirements is crucial for optimum engine protection. The engine air cleaners should be serviced after they have reached or surpassed an allowable restriction rise due to contaminant loading. Further, the point at which the engine air cleaners are serviced, affects both, filtration performance and overall vehicle performance. Engine air cleaners having excessive restriction values can significantly degrade the overall engine performance. It has been well demonstrated that the filtration efficiency of the air filter improves with contaminant loading. With an increase in efficiency, the engine wear significantly decreases. Servicing air filters at the recommended restriction rise, allows the filter to achieve its highest efficiency thus providing maximum engine protection. Too frequent servicing of the air filter, especially within the first 30 % of its service life can significantly increase engine wear [7].

In reality, engine air cleaners are prematurely serviced by the end customer. As a result the customer usually does not utilize the full value of the air filter. In this way the engine air filter never achieves its highest efficiency levels, thus reducing overall engine protection by increasing the rate of engine wear. Engine performance for light and medium vehicles generally requires that most engine air filters should be serviced, once the restriction rises and pressure drop after the filter has reached or exceeded about 2.5 kPa beyond the initial value of a new and clean filter [7]. The maximum air restriction or value of pressure drop can be expressed using the following formula [6]:

$$P_m = P_i + 2.5, \quad (1)$$

where P_m – maximum pressure drop, kPa;
 P_i – initial pressure drop, kPa.

Vehicle manufacturers may install air filter service indicators with settings between about 5.0 and 7.0 kPa [7]. It is possible to install such a device in aftermarket. Known makers of air filter service indicators are Engineering Products Co – maker of “Filterminder” brand, and Donaldson Company, Inc. “Servisignal” indicator of Donaldson Company shown in Figure 1 [8].



Fig. 1. Air filter service indicator

Several ways exist to find the maximum value of pressure drop for each vehicle and filter type:

- manufacturer data;
- value on OEM air filter service indicator;
- calculation of value according to formula (1).

Materials and methods

The test samples examined in this study were collected from vehicles used and serviced in Latvia. The testing was done in the Scientific Laboratory of Alternative Fuels, located in Jelgava.

1. Criteria of Test Sample Selection

For testing purposes engine air filters from two types of vehicles serviced in automaker Renault dealership “Musa Motors Riga” were collected. The selected vehicles were Master II, equipped with 2.5 liter Diesel engine G9U and Trafic II, equipped with 2.5 liter Diesel engine M9R. An essential criterion was the known mileage of filter use and that the filter is genuine Renault spare part. Filters replaced in the time frame from September 2010 till March 2011 of 31 Trafic II vehicles and 60 Master II vehicles were selected. All air filter samples have the record of vehicle identification, mileage and time of use. The reason for choosing these particular types of automobiles was relative popularity in Latvia and use as commercial transport, which leads to higher mileage and regular servicing. Both types of filters are dual stage filters made of pleated synthetic fiber paper media and using reticulated foam as prefilter. The total surface of the pleated part of the filter for Master II is 1.54 m², and for Trafic II – 1.47 m². At vehicle commercialization, the recommended maximum periodicity of replacement of filters was 40 000 km. Taking in consideration the limiting factors, such as vehicle use on unpaved roads, this periodicity was reduced to 20 000 km at the initial recommendations of the manufacturer. A comparison of new and used air filter cartridges is shown in Figure 2.

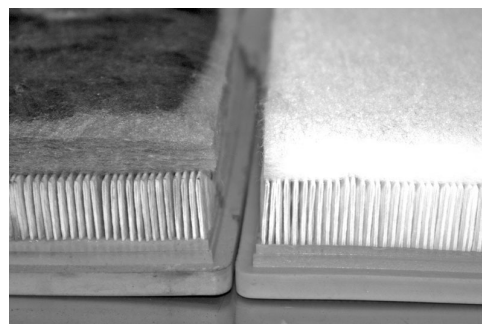

Fig. 2. Replaced and new air filter cartridges

Both types of sample filters were used in vehicles equipped with compression ignition, turbo charged engines. Maximum levels of air filter restriction are measured at high idle with no load for naturally aspirated and super-charged diesel engines. Turbo-charged diesel, gasoline and carbureted engines are measured at full load with a wide open throttle [7; 8]. The maximum value of pressure drop for vehicle Master II is found on OEM air filter service indicator, and its value is 6.22 kPa. The value for Traffic II has to be calculated, using formula (1).

2. Equipment and Test Setup

The testing was conducted on **Mustang MD1750** chassis dynamometer. The air pressure drop after the filter was measured as the difference of pressure in the air filter box upper part and atmosphere.

In Figure 3 the setup of air inlet circuit and the point of measuring the pressure drop are shown.

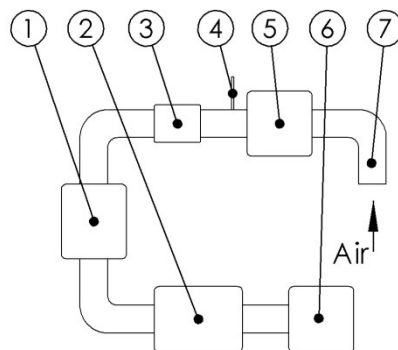

Fig. 3. **Schematic test setup:** 1 – turbocharger, 2 – air-air heat exchanger, 3 – flowmeter, 4 – pressure drop measurement point, 5 – engine air filter, 6 – engine intake manifold, 7 – air inlet

For pressure measurement the electronic pressure sensor was used. It was calibrated before the test using a water manometer. The testing of fuel consumption was done using the measurement system **AVL KMA Mobile**, in order to evaluate the influence of air flow restriction on fuel consumption.

3. Vehicle Testing

For correct testing of samples for a subject of air filter restriction, two vehicles were used, selected according to the filter types. The engine air inlet circuit of the vehicle Master II is shown in Figure 4 [9].

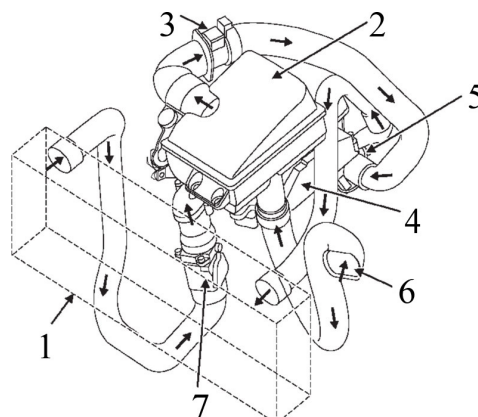

Fig. 4. **Engine air inlet circuit:** 1 – air-air heat exchanger; 2 – engine air filter; 3 – flowmeter; 4 – engine intake manifold; 5 – turbocharger; 6 – air inlet; 7 – damper valve

Before each test session, the vehicles were warmed up by driving for 10 minutes at speed $70 \text{ km}\cdot\text{h}^{-1}$.

The initial tests were provided in the following way. The vehicles were tested by driving in the 4th and 5th gear with the accelerator pedal fully pressed. The chassis dynamometer was used in constant speed mode. By stepping increase of the wheel rotation speed via dynamometer settings, and measuring the values of the engine power, torque, air flow and air pressure drop after the filter, it was possible to find the optimal range of the engine and wheel speed, at which the engine works at full load and the air consumption value is at maximum. The graph of initial testing of the vehicle Master II is shown in Figure 5.

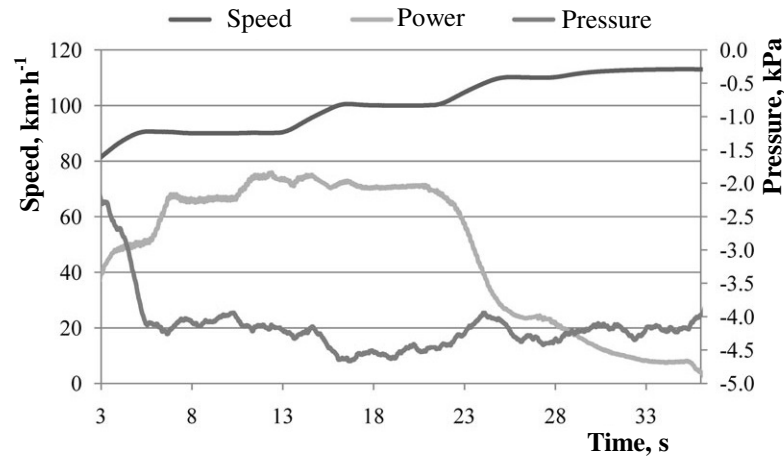

Fig. 5. **Evaluation of pressure drop:** at speed 100 km.h⁻¹ and gearbox at 4th gear, engine power and pressure drop are at maximum

Following a similar method, the vehicle Traffic II was tested, and optimal conditions for air filter restriction testing was at speed 110 km.h⁻¹ and gearbox at the 4th gear.

Results and discussion

The first series of testing were conducted using the vehicle Traffic II and corresponding collection of sample filters. The measurements of the engine power, torque and fuel consumption showed that a variation of air flow restriction within the range of sample collection has no impact on these parameters. Test using new filter cartridge gave air pressure drop at 2.81 kPa. It can be assumed, that according to formula (1), maximal pressure drop for this type of vehicle and filter is 5.31 kPa. As shown in Figure 6, no air filter sample was close to this value. That means, the chosen periodicity of air filter replacement for Traffic II with M9R engine is too short.

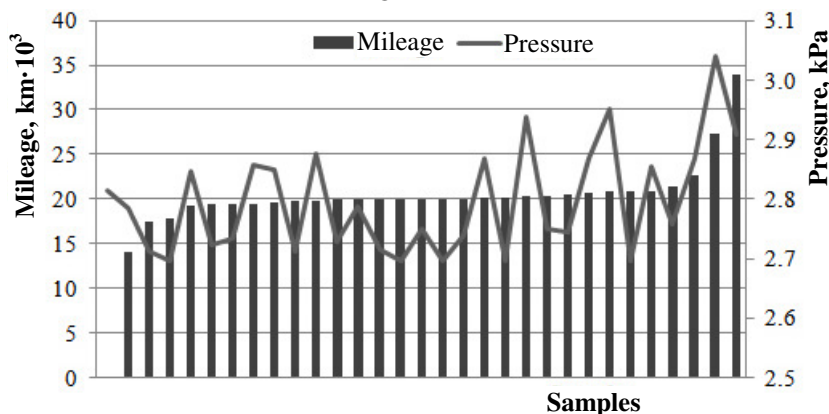

Fig. 6. **Measurements of air pressure drop for vehicle Traffic II**

Collection of air filter samples for vehicle Master II was larger, and contained items within a wider range of mileage and containment.

The measurement of engine power and torque also do not show significant impact on those parameters by air flow restriction within the range of sample collection. The air filter service indicator fitted by OEM is set to 6.22 kPa. The results of testing of the engine air filters used in the vehicle Master II with G9U engine are shown in Figure 7.

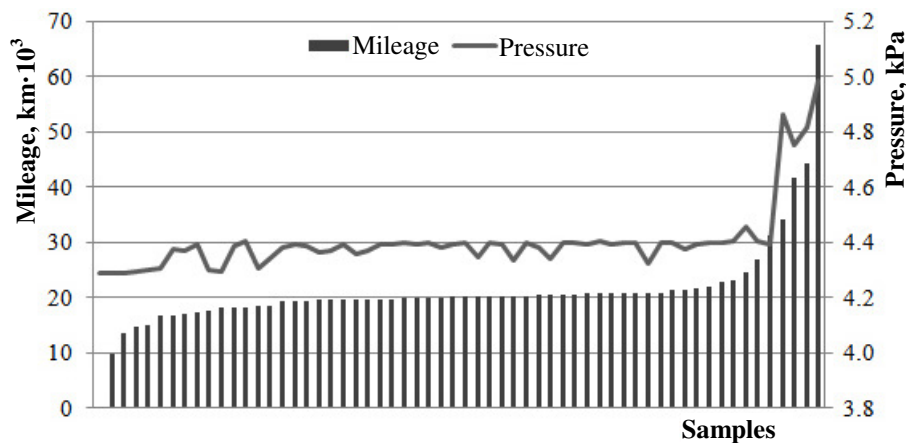

Fig. 7. Measurements of air pressure drop for vehicle Master II

According to the results, the engine air filters of the vehicle Master II, replaced at current periodicity 20 000 km, are replaced prematurely, before reaching restriction that could create 6.22 kPa pressure drop. This increases the cost of ownership and impact on environment.

Conclusions

1. The main criterion of engine air cleaner filter replacement is the value of air flow restriction.
2. Variations of air flow restriction within the recommended range do not have significant influence on the engine power and fuel consumption
3. Premature replacement of the engine air cleaner filter may increase engine wear and reduce its service life.
4. Periodicity of replacement of engine air cleaner filter cartridges on the tested vehicles types does not ensure complete utilization of the filter capacity and resource.

Acknowledgement

The paper was written by financial support of European Structural Fund – Support for Realization of Master Studies in the Latvia University of Agriculture.

Contract number 2009/0165/1DP/1.1.2.1.1/09/IPIA/VIAA/008.

References

1. Dagle John F., Brady Robert N. Diesel engine and fuel system repair. Fifth edition. London: Prentice Hall, 2002, 832 p.
2. Bauer Horst, Crepin Jurgen. Automotive Handbook. Fifth edition. Plochingen: Robert Bosch GmbH, 2000, 960 p.
3. Aizsils G. Dīzeļmotoru barošanas sistēmas. Jelgava: LLU, 2007, 202 p.
4. How filters work. Engineering Products Co (USA) information [online] [31.03.2011]. Available at: <http://www.filterminder.com/howfilterswork.asp>
5. Neville J. Bugli, Automotive Engine Air Filters – Performance Trends. Detroit: SAE, 2001, 10 p.
6. Brian West, Kevin Norman, Shean Huff. Effect of Intake Air Filter Condition on Vehicle Fuel Economy. Oak Ridge: National Laboratory, 2009, 40 p.
7. Neville J. Bugli, Gregory S. Green, Performance and Benefits of Zero Maintenance Air Induction Systems. Detroit: SAE, 2005, 16 p.
8. Filter Indicators and Gauges. Donaldson Corporation, Inc (USA) information [online] [31.03.2011]. Available at: <http://www.donaldson.com/en/engine/support/datalibrary/053979.pdf>
9. Renault Master II – Repair Manual [online] [31.03.2011]. Available at: <https://dcs.renault.com>.