

COMPENSATED SINGLE PHASE RECTIFIER

Jānis Doniņš, Jānis Greivulis

Riga Technical University, Faculty of Power and Electrical Engineering,
Institute of Industrial electronics and electrical engineering
jdonins@gmail.com, greivulis@eef.rtu.lv

Abstract. The research paper discusses pulsation reduction method for rectifier bridge circuit, and provides mathematical analysis and simulation. The converter is designed to get steady direct voltage at wide range load resistance. The simulation is performed using PSIM computer simulation software. The simulation and real model output current and voltage graphs are acquired and given.

Key words: pulsation reduction, voltage multiplier, rectifier bridge circuit.

Introduction

Single phase compensated rectifier with nonlinear active-inductive load character is simplified case of three phase controllable, compensated rectifier. Device is related to converters of electrical energy and it can be used in power electronics. Purpose of single phase compensated rectifier is to reduce load current pulsations.

Solution additionally consists of voltage multiplier, which input is connected parallel to rectifier bridge and to power transformer output. Output positive pole of voltage multiplier is connected to rectifier bridge output positive pole through the compensation control switch and separation diode. Rectifier bridge and multiplier output negative poles are connected directly.

Regulator switch is operated so that rectifier output voltage pulsation is minimal and its value is kept close to $U_{d\ max}$. This current pulsation reduction effect is achieved so that voltage multiplier capacitors with doubled voltage are used as an additional power source for load chain.

Operation of regulator switch is controlled by comparing of two voltages, pitch voltage U_{pitch} and voltage on load. While these voltages are equal or U_d is greater than U_{pitch} , load current is not regulated. As soon as load voltage less than U_{pitch} voltage value, the voltage regulator is switched on. Load voltage regulation process is continuous.

Research object and methods

Research object is AC to DC converter which consists of rectifier bridge, ripple compensation unit and electronic switch that drives output direct voltage regulation, see Fig. 1. Inductive and resistive load is connected to converter output. One of sources that feeds load is rectifier unit that has pulsating output voltage and current values. Voltage regulation unit is designed to reduce these pulsations and keep it up to $U_{d\ max}$ value.

For mathematical analysis circuit is simplified, we do not consider comparing and switching unit control circuit, because it is relatively small, also diodes are assumed to be ideal. Mathematical analysis is performed only for DC side. DC side actually consists of two circuits (Fig. 2).

On the left (Fig. 2) voltage source u_d describes rectifier output voltage. In the middle of circuit is placed load that is series connected inductor and resistor. On the right there are two series connected capacitors of voltage multiplier and regulator switch. Each capacitor of voltage multiplier is charged approximately with $U_{d\ max}$ voltage. So the load voltage is compensated with doubled voltage. These capacitors are loaded continuously from AC side and discharging to DC side when load voltage is less than $U_{d\ max}$ voltage value.

For simulation of single phase compensated rectifier PSIM software is used. PSIM is a simulation package specifically designed for power electronics and motor control. The circuit and its parameters for simulation are shown in Fig. 1.

The real circuit is built too, so the results of all research methods are compared.

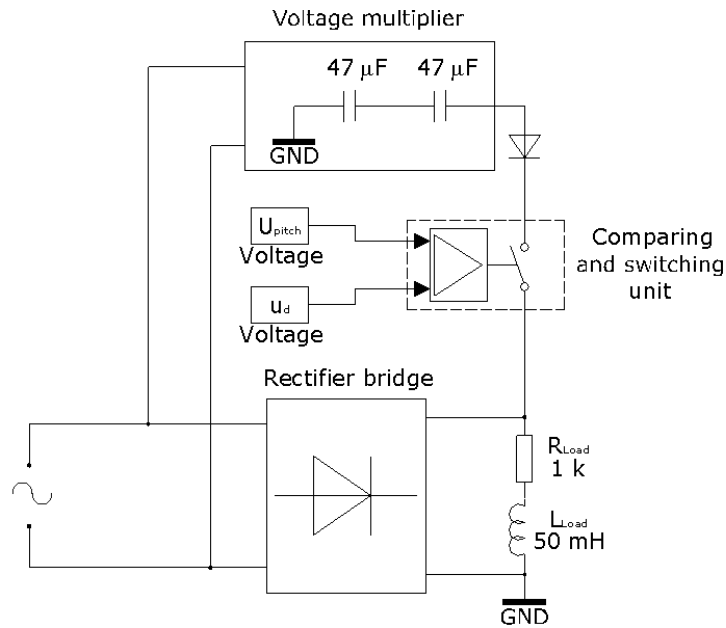

Fig. 1. Compensated single phase AC to DC converter

Mathematical analysis and simulation

In order to provide analysis at first solution of each of two circuits in Fig. 2 must be found. The first circuit to solve is shown in Fig. 3. The second circuit to solve is shown in Fig. 3. Then merging these results, common solution must be found, that is definable with these both current changing conditions.

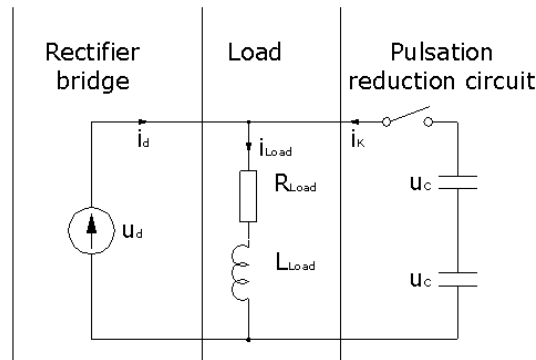

Fig. 2. Mathematical analysis circuit

The solution of first circuit must find current on RL load. The source of circuit is simple rectifier bridge. Its input voltage is sinusoidal voltage and output is pulsating direct current. Equation that defines character of this current is shown further.

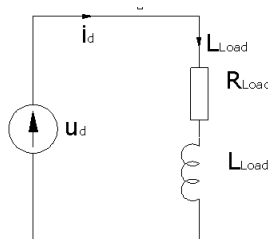

Fig. 3. Mathematical analysis of rectifier bridge with RL load

Obviously in this mode every single diodes are operate independently of other diodes, on this account the differential equation of rectified voltage at one conducting (ideal) diode is following

$$u_d = L_{Load} \frac{di_d}{dt} + i_d R_{Load}, \tag{1}$$

After finding integration constant, and performing all necessary transformations, the complete solution of first circuit current characterizing equation is following

$$i_d = \frac{U_m}{R_{Load}} \cos \alpha_e \left[\sin(\varphi - \alpha_e) + \frac{2 \sin \alpha_e e^{-\frac{\varphi}{\text{tg} \alpha_e}}}{1 - e^{-\frac{\pi}{\text{tg} \alpha_e}}} \right]. \tag{2}$$

The solution of second circuit when capacitor discharges to resistive and inductive load is found as follows. In the starting position $t=0$ there is assumed that both capacitors are charged each with $U_{d \max}$ voltage for mathematical analysis. The mathematical analysis circuit for this process is presented in Fig. 4.

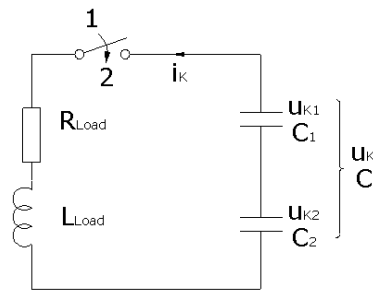

Fig. 4. Mathematical analysis of capacitor discharge circuit with commutation

Common parameters U_C ; C of both capacitors are found $C = \frac{C_1 + C_2}{2}$;

$U_K = U_{K1} + U_{K2} = 2U_{d \max}$. At start-position when $t = 0$, both capacitors are charged, the switch is being switched from position 1 to position 2. Now the transition stage can be calculated. The integral-differential equation that describes this process is constructed:

$$L_{Load} \frac{di_{K.free}}{dt} + R_{Load} i_{K.free} + \frac{1}{C} \int i_{K.free} di_K = 0 \tag{3}$$

The roots of this equation:

$$p_{1,2} = -\frac{R_{Load}}{2L_{Load}} \pm \sqrt{\frac{R_{Load}^2}{4L_{Load}^2} - \frac{1}{L_{Load}C}} \tag{4}$$

Enforced mode capacitor voltage $U_K = 0$, transition process will end with full capacitor discharge for mathematical analysis in general case. Performing all necessary operations to solve equation (3), the results are achieved. Transition process voltage for capacitors:

$$u_K = \frac{U_0}{p_1 - p_2} (p_2 e^{-p_1 t} - p_1 e^{-p_2 t}) \tag{5}$$

where $U_0 = 2U_{d \max}$.

The converter output voltage can be characterized with following equation in case when both circuits are connected to load without voltage regulation:

$$u_{d.K} = L_{Load} \frac{di_d}{dt} + i_d R_{Load} + u_K \tag{6}$$

Equations (2) and (5) are inserted into (6), and considering that $t = \frac{\alpha}{\omega}$, complicated equation is acquired. Mathematical analysis is finished, because the further analysis is very difficult.

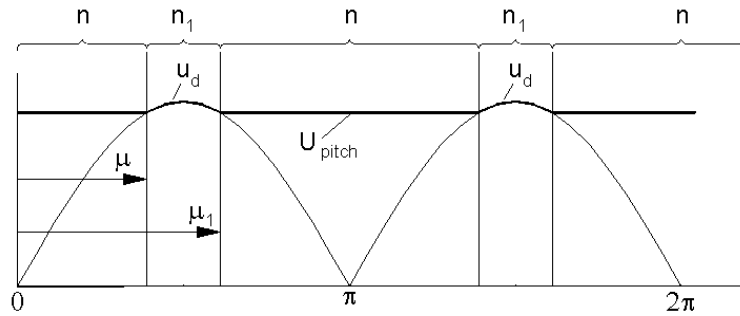

Fig. 5. Diagram to determinate regulation areas

Converter output voltage and current consists of areas n and n_1 , they are changing sequential, this voltage area change is determinates angles μ and μ_1 . If the compensation voltage is higher, then rectifier voltage, its voltage drops to 0. Then only the capacitor voltage is connected to load, and this is area n , see Fig. 5. If the capacitor voltage is lower, then rectifier voltage, then compensator voltage drops to 0. This is because the conducting diodes of rectifier and diode of multiplier output goes into non-conducting mode if voltage on diode changes direction. Equation (6) describes current for n area, and equation (2) for n_1 area. The voltage U_{pitch} is regulator pitch voltage. The angle when regulator is switched of is following:

$$\mu = \arcsin\left(\frac{U_{pitch}}{U_{d.max}}\right) + \pi_n \quad (8)$$

The angle when capacitor's voltage is switched and regulated to load expressible with μ_1 :

$$\mu_1 = \mu + 2\left(\frac{\pi}{2} - \mu\right) + \pi_n \quad (9)$$

where π_n - number of period.

These angles are the same for load voltage and current. The simulation and real model oscilloscope graphs are shown in Fig. 6, 7 and 8. The parameters of these experiments are shown in Fig. 1.

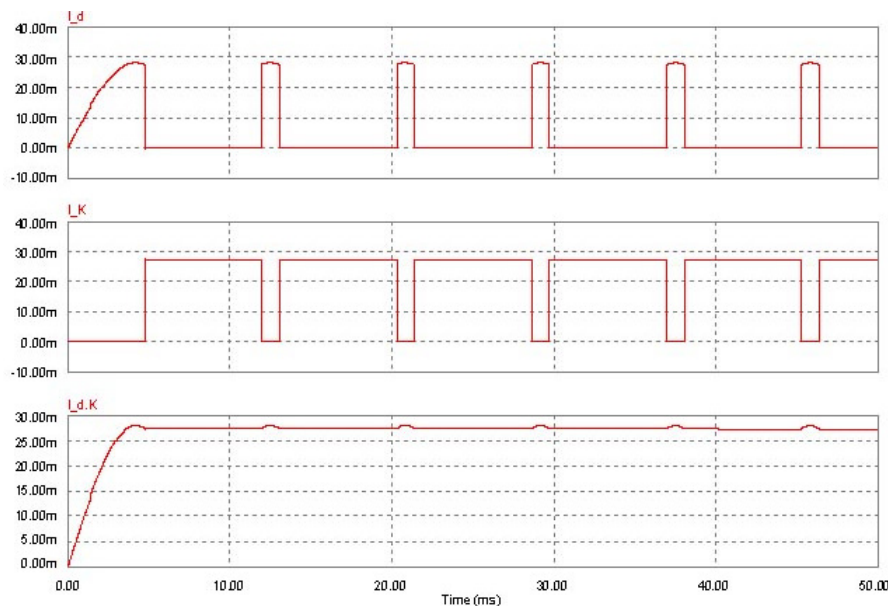

Fig. 6. PSIM simulation rectifier, regulator and output currents

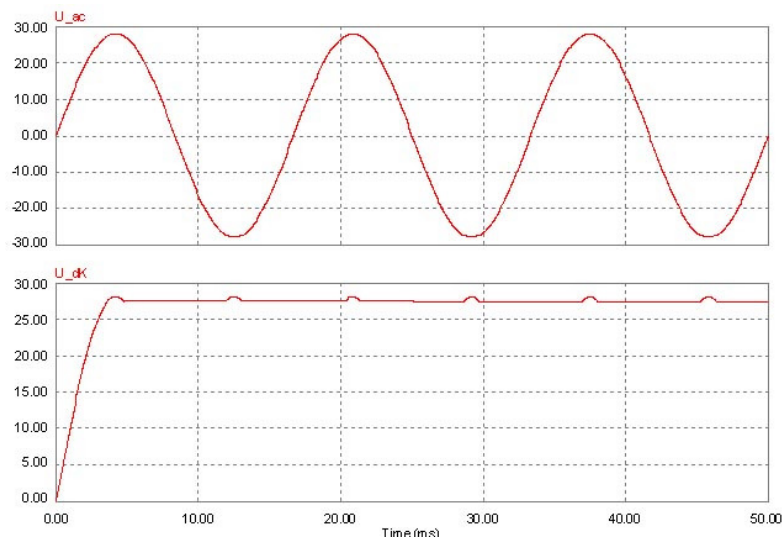

Fig. 7. PSIM simulation input and output voltage graphs

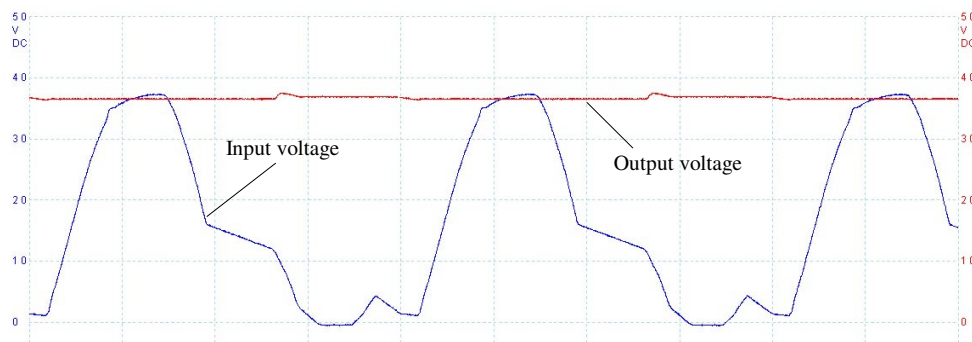

Fig. 8. Real model simulation results, input and output voltages

Conclusions

1. Experimental circuits give steady direct voltage on load, when active resistance is in range from 1 k Ω . The simulation model shows better results, it gives a steady direct voltage even if active resistance is in range from 350 Ω . Real model can be improved lowering regulator circuit current.
2. Using capacitance as simple filter, gives no effect for pulsation reduction, combined with doubled voltage regulator, filter acts as parasite capacity, but small filter capacity is useful to reduce regulator noise.

References

1. V. Putniņš, J. Greivulis, E. Blumbergs, G. Leiškals. Stiprās strāvas rūpnieciskā elektronika, Izdevniecība "Liesma" Rīga 1978, 245 pages.
2. I. Dūmiņš, M. Eizentāle, I. Matīss, N. Nadežņikovs, K. Tabaks, K. Tabaka red. Elektrotehnikas teorētiskie pamati – Pārejas procesi garās līnijās un nelineārās ķēdēs, Rīga "Zvaigzne" 1989, 352 pages.
3. И. М. Чиженов, В. С. Руденко, В. И. Сенько, Основы преобразовательной техники, Издательство „Высшая школа”, 1974, 426 pages.
4. Г. Сю Зиновев, Основы силовой электроники. Новосибирский государственный университет, Новосибирец, 2002.