

## WEAR RESISTANCE OF MULTI-LAYER OVERLAYS

Milan Brozek

Czech University of Life Sciences Prague

brozek@tf.czu.cz

**Abstract.** The phenomena connected with wear and friction processes are the most often the reason of machine parts damage. Therefore, the possibilities of the exposed machine parts life increase are searched for. One of them is the use of special wear resistant overlays on the functional machine parts surfaces. But the producers and dealers do not provide data about overlays regarding their wear resistance. Searching the optimum solution, it proceeds usually from the own experimental results. In the paper the laboratory abrasion resistance test results of chosen hard facing materials using the pin-on-disk abrasion testing machine are published. Overlays of three different electrodes made in one, two and three and in one case in five layers were tested. The evaluations of the wear resistance, abrasive particles size influence and relation between hardness and wear resistance were the aim of the carried out experiments.

**Keywords:** overlay, wear, wear resistance, laboratory tests, pin-on-disk machine.

### Introduction

According to the statistical data on agricultural repairs, as much as 90 % of all damaged parts are put out of service by the reason of excessive wear and about 80 % is shut down due to abrasive wear. Among the typical parts of agricultural machinery exposed to abrasive wear during operation are functional parts of machines used for soil cultivation (e.g., plough shares, rotary hoe knives etc.) and harvesting (digging blades, potato digger disks, reaping adapter parts etc.). Therefore, it is necessary to take measures to improve the abrasive resistance of these parts while keeping a sufficient strength of their cutting edge impact resistance. In practice there are several methods for solving this task - from the substitution of less resistant materials by more resistant ones to generating more resistant surface zones through heat treatment, metal coating, metal plating, brazing, surfacing or metal spraying, using materials with special properties on functional surfaces [1 – 3].

As it follows from the above, the surfacing technology, i.e., making a special wear - resistant overlay on the functional part surface, is one of the possibilities of upgrading the wear resistance (or decreasing wear). In practice, two methods of overlaying technology are used:

- for preventive overlays – overlay application in manufacturing of new parts in factories; the aim is to generate a surface that is more resistant to wear, corrosion, high temperature and suchlike,
- for renovation – overlay application in renovation of used parts (worn material is made up); the aim is to renew the functional properties of the parts and at the same time to upgrade their wear, corrosion or heat resistance, if needed [4 – 7].

In both cases, suitable use of overlays may bring significant economic effects, namely:

- material and power saving – production of new parts demands more material and more power than surfacing of one or more worn parts;
- labour consumption reduction – machining one or more functional surfaces after their surfacing is more simple than machining all surfaces in new part production; in some cases overlays can be used without further finish (e.g., surfacing parts of agricultural machines for soil cultivation);
- working life improvement of a surfacing part – a suitable weld material for the given operating conditions of a particular part can be chosen from the offer. Consequently, this part can have a substantially longer service life compared with the original one, so the frequency of worn out parts changes, outage time at renovation etc. can be reduced [2 – 4].

The surfacing of layers with special properties using the weld materials of various shapes (electrodes, wires, tube wires, strips cladding, gas rods, powders) is one of fast developing applications of the surfacing technology. It is used not only in agriculture, but also in building industry, mineral working, transport, material operation and many other branches of human activity. For the optimum use of surfacing detailed know-how of the weld material technique and technologic

properties and their behaviour in different working conditions is necessary. These data together with economic materials are the most important criteria for evaluating the use of overlays.

Wear is a complicated process, defined as „permanent undesirable surface (dimension) change, caused by functional surfaces, or by a functional surfaces and wear medium“. It shows itself as particles removal or relocation from the worn out surface by mechanic effect, and may be accompanied by other influences (e.g., chemical, electrochemical and electrical). Wear is classified into six basic types: adhesive, abrasive, erosive, cavitation, fatigue, and vibrating. In addition, there are other types which are a combination of the mentioned ones (ČSN 01 5050, 1969) [8]. In practice, however, all types never appear at once. Usually one type is dominant and the other one can cooperate. In agriculture, for example, abrasive wear is the most significant type, characterized by the action of hard particles (e.g., sand in soil, dust present in most agricultural operations) on worn out surfaces.

The wear resistance values of a particular weld material are not available to customers (firm publication). Catalogues give only a notice “wear resistant“ or “excellent resistant to combinations of heat, abrasion, corrosion and erosion“. However, wear resistance can not be described by a single value without determination of the test conditions. The dominant wear conditions are determined:

- by the type and properties of abrasive and abraded surfaces, characteristics of contact surfaces, state and properties of surface and subsurface areas, wearing medium,
- by characteristic of the motion type,
- by characteristic of load,
- by characteristic of environment.

From the enumeration of the affected factors it is evident that wear resistance is a very complicated material property and thus its determination is demanding [2].

In order to determine wear resistance to various types of wear, production and laboratory tests are used. Each of the above-mentioned methods has advantages and disadvantages, as well as the most suitable range of application. The wear resistance testing method must be chosen with respect to the dominant wear conditions and required test results. Production tests [4; 6] are conducted in a real environment. They make it possible to study and assess wear directly in machine parts of functional groups. But the results are often influenced by operation factors variability. The results are applicable only to a concrete engine plant or a machine working under similar conditions. Using production tests for a study of wear is more costly and time-demanding than laboratory tests. Based on processing the statistical data of production tests, it is possible to predict the service life of single parts or functional groups. Laboratory tests usually make it possible to simulate only some of the wear process parameters [9; 10]. Therefore, their results can be applied to practice only after a thorough analysis of real service conditions. Laboratory tests, however, make it possible to study an influence of single factors on the wear character and rate. Among their advantages there are minor costs and good test reproducibility [3; 11].

In literature a sufficient number of wear resistance testers for various types of wear is mentioned [3; 11]. The testing equipment for abrasive wear determination is usually classified according to the contact mode on equipment with free or bonded abrasives. In practice, the testing machines with abrasives bonded to cloth (Fig. 1) [12] are used most often. They are simple and reliable, with small variance in results. Their disadvantage is the variable quality of abrasive cloth. In the Czech Republic this testing method is standardised according to ČSN 01 5084 (similar foreign standards: STN 01 5084, ASTM G 132) [11].

### **Materials and methods**

In the paper the laboratory wear resistance tests results of three types of electrodes for manual welding, namely E-B 508, E-B 518 and E-B 519, are published. All these hard facing electrodes are determined for cladding of wear resistant overlays. Their producer, firm ESAB, recommends their cladding maximum in three layers [13].

The wear resistance evaluation of the above mentioned overlays was the aim of the carried out experiments. The test specimens of each electrode type were made with one, two and three and at the electrode E-B 508 with five layers.

The overlay structure of the electrode E-B 508 comprises fine martensite and retained austenite, electrode E-B 518 mixture of Cr carbides, fine martensite and austenite, electrode E-B 519 tempered martensite and acicular Cr carbides.

The evaluation of the abrasive particles size influence on the wear intensity and the evaluation of the relationship between the hardness and wear resistance of the overlays were a part of the carried out experiments.

All above mentioned electrodes were welded on according to the producer instructions. The steel 11 373 ( $C_{\max} = 0.17\%$ ;  $Ni_{\max} = 0.007\%$ ;  $P_{\max} = 0.045\%$ ;  $S_{\max} = 0.045\%$ ) according to CSN 41 1373 [14] was the basic material. This steel answers, e.g., the steel 11373 according to STN 41 1373, the steel FeFe360B according to ISO 4360-86 and BS 4360-86, the steel Fe 37B1FN according to Euro, the steel USt37-2 according to DIN 17100-80 or the steel Gr.C according to ASTM A283-78.

The chemical composition of the basic material and chemical composition of single overlay layers are presented in Tab. 1.

Table 1

**Chemical composition of the basic material and welded on layers**

Tested material	Chemical composition, weight %				
	C	Si	Mn	Cr	Mo
11 373, basic material	0.085	0.220	0.420	0.140	0.017
E-B 508, 1 <sup>st</sup> layer	0.56	0.49	0.73	4.39	0.35
E-B 508, 2 <sup>nd</sup> layer	0.64	0.48	0.80	5.86	0.43
E-B 508, 3 <sup>rd</sup> layer	0.63	0.51	0.84	6.29	0.44
E-B 508, 5 <sup>th</sup> layer	0.60	0.39	0.82	6.81	0.48
E-B 508, catalogue	0.5	0.5	0.7	6.0	0.6
E-B 518, 1 <sup>st</sup> layer	3.50	0.64	0.52	24.72	x
E-B 518, 2 <sup>nd</sup> layer	3.70	0.67	0.49	25.68	x
E-B 518, 3 <sup>rd</sup> layer	3.68	0.74	0.55	26.02	x
E-B 518, catalogue	3.4	0.8	0.5	29.0	x
E-B 519, 1 <sup>st</sup> layer	2.61	1.15	0.64	17.64	x
E-B 519, 2 <sup>nd</sup> layer	3.35	1.32	0.65	20.98	x
E-B 519, 3 <sup>rd</sup> layer	3.11	1.40	0.66	22.97	x
E-B 519, catalogue	3.5	2.0	0.9	24.0	x

The test process and evaluation. The principle of an abrasive wear test using the pin-on-disk machine with abrasive cloth (CSN 01 5084; Fig. 1) [11; 12] is to wear the specimen under pre-determined conditions. The test specimen is pressed against an abrasive surface using the prescribed normal force. The wear path is a spiral on the disk, caused by the disk rotation and a radial feed of a specimen, so the specimen progressively moves over unused abrasive along the prescribed track length.

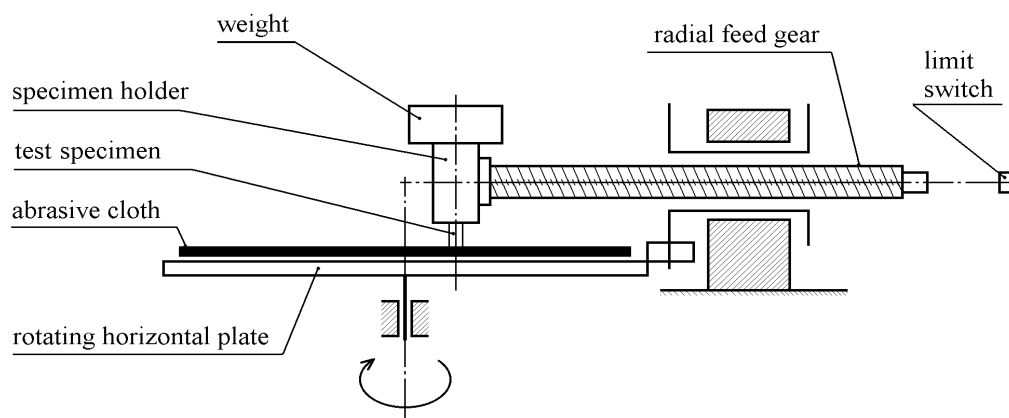

Fig. 1. Scheme of the abrasion testing machine (pin-on-disk)

The reference specimens are made from the steel 12 014.20 according to ČSN 41 2014 [15] [similar, e.g., steel 12014 (STN 12 014), 10880 (GOST 3836), ELFE 100 (MSZ 8628) or E3 (PN H92133)] of the hardness from 95 to 105 HV 30.

As the abrasive cloth the corundum twill type A 99 – G, S 25, trade mark Globus, grit 120, was used. In addition tests using the grits 60 and 240 were carried out, too. It corresponds to the average abrasive grain sizes of 44.5 (grit 240), 115.5 (grit 120) and 275  $\mu\text{m}$  (grit 60).

During testing the abrasive cloth is fixed on the disk, the test specimen is fixed in the holder and pressed against the abrasive surface by weight. After machine inspection the tests may begin. For relative wear resistance determination the reference specimens are used, which eliminate errors caused by the different abrasive cloth quality. The tests are opened with two reference specimens, which are not evaluated. Then the specimens and reference specimens periodically alternate according to the scheme 1 – 2 – 1 – 2 – 1 etc. The test runs out using one reference specimen.

The specimens are weighted before and after the test to an accuracy of  $10^{-3}$  g. The HV hardness of all specimens is measured, too (Fig. 2).

The tested material relative wear resistance  $\psi_{abr}$  (Fig. 3) is calculated using the equation

$$\psi_{abr} = \frac{W_{hPZ}}{W_{hZ}} \quad (1)$$

where  $W_{hPZ}$  – mean mass defect of etalon, g;

$W_{hZ}$  – mean mass defect of tested specimens, g.

## Results and discussion

The test results are graphically presented in Figs. 2, 3 and 4.

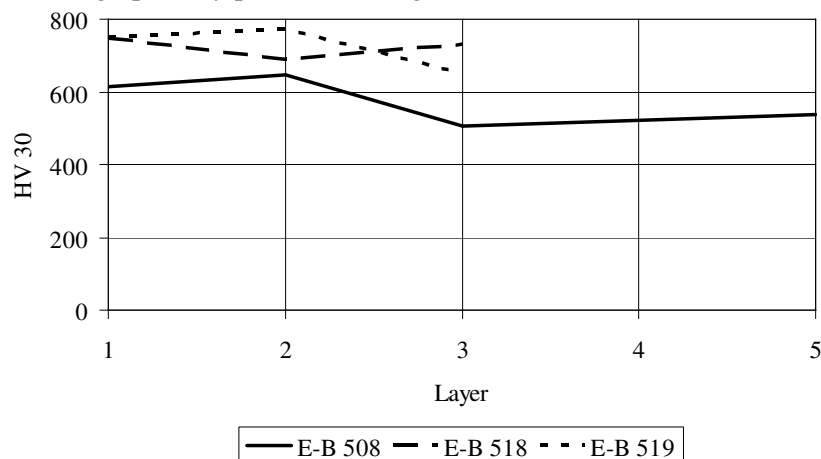

Fig. 2. Hardness HV30 of single overlay layers

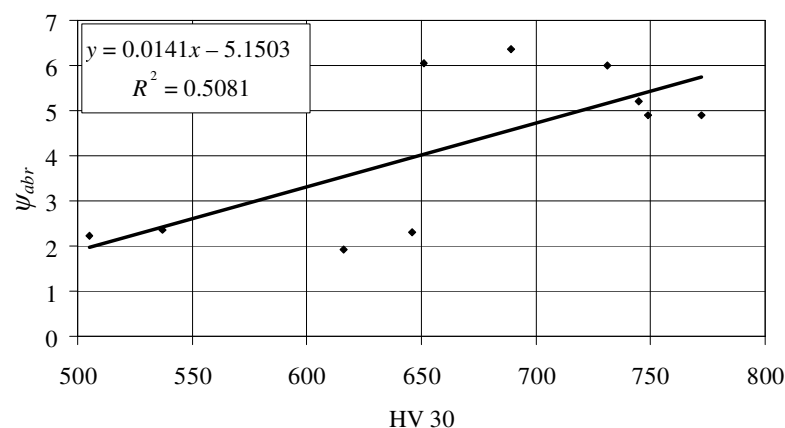

Fig. 4. Dependence of the relative abrasion wear resistance  $\psi_{abr}$  of the overlay single layers on the hardness HV 30

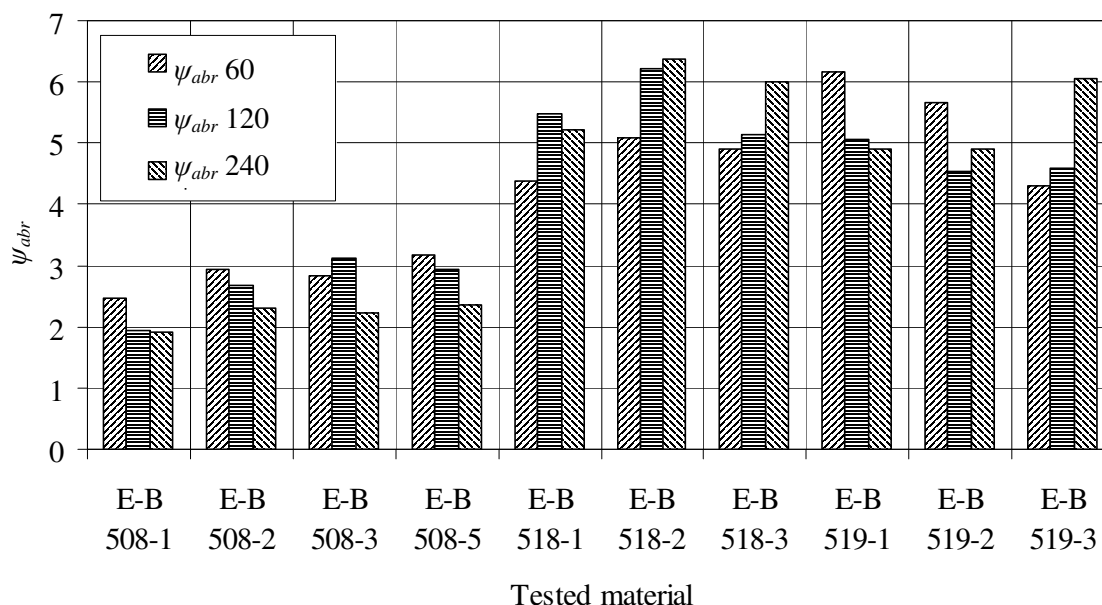

Fig. 3. Dependence of the relative abrasion wear resistance  $\psi_{abr}$  of single overlay layers on the abrasive particles grit

From the results it follows that each of the chosen overlay materials is of different properties.

The overlay hardness (Fig. 2) was in the first layer from HV 30 = 616 (E-B 508) to 749 (E-B 519). At both of these materials the hardness increased after the overlaying of the second layer, namely up to HV 30 = 646 (E-B 508), respectively up to HV 30 = 772 (E-B 519). But after the overlaying of the third layer the hardness of both electrodes decreased to the lower value than it was the hardness of the first layer, namely to HV 30 = 505 (E-B 508) respectively to HV 30 = 651 (E-B 519). After the overlaying of the fifth layer using the electrode E-B 508 mild hardness increase occurred, compared to the hardness of the third layer, to the hardness HV 30 = 537, nevertheless, the hardness of the first layer was not reached. The situation using the electrode E-B 508 was rather different. The hardness of the first layer was HV 30 = 745, after the overlaying of the second layer the hardness decreased to the value of HV 30 = 689. After the overlaying of the third layer the hardness mild increased up to HV = 731, nevertheless the hardness of the first layer was not reached. From the point of view of the maximum attainable hardness it is possible to recommend the use of two layers overlays made by use of the electrodes E-B 508 and E-B 519 and one layer overlay made by use of the electrode E-B 518.

Fig. 3 presents the dependence of the values of the relative abrasion resistance  $\psi_{abr}$  of the three tested electrodes single layers on the abrasion particles grit. From the results of the electrode E-B 508 the trend of the wear resistance increase with the increasing layers number is evident. But the results of the different abrasion particles size are considerably different. For large particles (grit 60, mean particle size 275  $\mu\text{m}$ ) the highest wear resistance is found only in the fifth layer, for medium-sized particles (grit 120, medium particle size 115.5  $\mu\text{m}$ ) in the third layer and for small particles (grit 240, mean particle size 44.5  $\mu\text{m}$ ) in the second layer. The result of the overlay made using the electrode E-B 518 is interesting, when for all three particle sizes the highest relative wear resistance  $\psi_{abr}$  was determined already in the second layer. Using the electrode E-B 519 the highest wear resistance was determined for large and medium-sized particles already in the first layer. But at small particles the highest wear resistance was reached only at the third layer.

From Fig. 3 it is also evident that the overlays from the electrode E-B 508 are the least wear resistant. The value  $\psi_{abr}$  ranges from 1.91 to 3.17. Considerably higher, about twice as high relative wear resistances were determined at both remaining electrodes, E-B 518 and E-B 519. At the electrode the value  $\psi_{abr}$  ranges from 4.37 to 6.36, at the electrode E-B 519 from 4.29 to 6.17. The highest wear resistance was determined at the overlay from the electrode E-B 518 in the second layer at wear by small particles (grit 240, mean grain size 44.5  $\mu\text{m}$ ).

From the foregoing results it is evident that from the point of view of the structure the martensite structure is less advantageous. Considerably better results were reached at overlays containing chromium carbides.

The dependence between the wear resistance  $\psi_{abr}$  and the hardness HV 30 is interesting. As it follows from Fig. 4 between these two properties only a weak dependence ( $R^2 = 0.51$ ) was determined. Therefore, from mere surface hardness measurement the wear resistance of the concrete overlay cannot be considered. For reliable assessment it is necessary to carry out relatively demanding laboratory or working tests.

## Conclusions

The results of all carried out tests confirmed that the wear resistance is a very complicated material characteristic. Therefore, the wear resistance evaluation cannot be replaced by any other simple tests. Always it is necessary to carry out laboratory or working tests. At the same time it is possible to agree with the producers' advice about the use of maximum three layers at this type of overlays.

## References

1. Chasuj, A., Morigaki, O.: Naplavka i napylenije. (Surfacing technology). Moskva, Mašinstrojenije 1985. 240 p. (In Russian).
2. Vocel, M.: Návrh materiálové volby na strojní součásti pracující v intenzivní abrazi. [Výzkumná zpráva]. (The material selection project for machine parts working in intensive wear area. Research project). Prague, SVÚM 1978. 26 p. (In Czech).
3. Vocel, M., Dufek, V. et al. Tření a opotřebení strojních součástí (Machine parts friction and wear). Prague, SNTL 1976. 376 p. (In Czech).
4. Brozek, M. Technicko – ekonomické hodnocení aplikace návarů u plužních čepelí (Technic-economical Evaluation of the Overlays Application on the Plough Shares). Acta univ. agric. et silvic. Mendel. Brun., 2007, LV, No. 4, pp. 129 – 136. (In Czech).
5. Havlicek, J. et al. Provozní spolehlivost strojů (The serviceability of machines). Praha/Bratislava, SZN/Príroda 1989. 616 p. (In Czech).
6. Legat, V. et al. Hodnocení jakosti orby a plužních čepelí (The evaluation of ploughing and plough shares quality). Research project ČZU 309/10/16196/0. Prague, Czech University of Life Sciences Prague 1999. 28 p. (In Czech).
7. Repair and Maintenance Welding Handbook. ESAB AB, 120 p.
8. ČSN 01 5050. Opatřbení materiálu. Názvosloví. (Wear of materials. Terminology). 1969. (In Czech).
9. rozek, M., Novakova, A., Mikus, R.: Study of wear resistance of hard facings using welding powders on the NiCrBSi basis. In.: Trends in Agricultural Engineering (TAE) 2010. Prague, Czech University of Life Sciences Prague. pp. 115 – 118.
10. Suchanek, J., Blaskovits, P., Brozek, M. Abrasion Resistance of Selected Hardfacing Materials. Trends in Agricultural Engineering. Prague, CUA - Technical Faculty 1999. pp. 606 – 610.
11. Friction and Wear Testing. American Society for Testing and Materials, West Conshohocken, PA, 1987. pp. 186.
12. ČSN 01 5084. Stanovení odolnosti kovových materiálů proti abrazivnímu opotřbení na brusném plátně (Determination of metal material resistance against wear by abrasive cloth). 1974. (In Czech).
13. Brozek, M. Layer number influence on weld deposit chemical composition. In.: 10th International Scientific Conference Engineering for Rural Development. Jelgava, Latvia University of Agriculture. 2011, pp. 393 – 397.
14. ČSN 41 1373. Ocel 11 373. (Steel 11 373). 1994. (In Czech).
15. ČSN 41 2014. Ocel 12 014. (Steel 12 014). 1993. (In Czech).