

DEFORMATIONS OF STEEL CONSTRUCTIONS IN PROCESS OF WELDING BY MAG TECHNOLOGY

Gunars Verdins, Daina Kanaska, Valdis Kleinbergs

Latvia University of Agriculture

gunars.verdins@llu.lv, daina.kanaska@llu.lv

Abstract. Dimensional deformations of steel beam after MAG welding are analytically calculated as well as verified by experiment results. There are key factors defined, which have an effect on the value of deformation as well as solutions offered for regulation of the value of deformation in dependence on the welding technology and by selection of the regime.

Key words: welding, deformations.

Introduction

The development of technology for manufacturing of steel constructions is a fairly complicated process, especially in cases, when the product has to be with small tolerances of dimensions as well as high precision geometrical deviations of surfaces of parts. The problems arise already at the moment, when the size dimensions of separate blanks, which are welded together, are defined. The designer has to provide how much the dimensions of separate parts and final sizes of the product will change in the welding process, as well as what will dispersion of the dimensions after welding be, becoming cold and leveling of stress in the construction. It is established that the main reason of deformations of the process of welding are stresses which appear as a result of irregular impact of heat to material. As a result of the temperature effect the mechanical characteristics of the material are changed: tension strength, yield point as well as module of elasticity. Geometrical dimensions of the parts have important influence on the process of appearing of deformations.

The field of interest of designers and technologists is to predict and calculate deformations, which can arise in the process of manufacturing of a particular construction as well as how to prevent or regulate it.

The modeling of the welding process faces hardships, which are not solved till now. It is fairly complicated to evaluate correctly the development of permanent deformations, resulted by stresses, which exceed the yield point, as well as the changes of the field of temperature by time in conditions, when a moving source of heat is used; to evaluate the process of heat exchanging with surrounding environment, the development of plastic deformations, specific characters by welding of different materials, as well as the factors of welding, which change by using of different methods, environment etc [1; 2]. In the process of working out of concrete welding technology empiric coherences have to be used, which are based on the standards, normatives of the field, experimental results, correspondence of the technology practically has to be verified, as well as errors in the dependence on the acquired results should be checked [3].

Materials and methods

For estimation of deformations and displacement, which occur in the process of welding, it is accepted that the weld is welded on all its length; the task is separated in two parts: thermo mechanical and deformation. The task of the thermo mechanical part is to estimate the rate of the shrinkage force, cross shrinkage as well as other elements of deformation, which occur in the welded joints. The task of the designer is to estimate the deformations and displacement by using of the methods of material strength, for example, the fictive forces method, when the impact of the shrinkage force on the construction is replaced by the outside fictive force.

After estimation of the shrinkage force and the width of the plastic deformation area, with certain validity it is possible to define deformations of the construction, which occurred in the process of welding.

When low carbon steels are welded the shrinkage force increases, but the rigidity of the construction decreases. For estimation of the shrinkage force P_{ruk} coherence [3] was used:

$$P_{ruk} = q/v_c, \quad (1)$$

where q – effective power of heat source, $J \cdot s^{-1}$, which for the welding processes can be expressed as: $q = \eta \cdot I \cdot U$;
 v_c – speed of welding, $cm \cdot s^{-1}$;
 η – efficiency of welding equipment;
 I – current intensity;
 U – voltage.

In multilayer weld the force of shrinkage decreases about 1 % with welding of the each next layer [3], this value is taken into account in the final result by multiplication with the appropriate coefficient.

For calculation of the deformation the methods of material strength are used. Longitudinal deformation of weld Δl can be expressed as:

$$\Delta l = P_{ruk} \cdot l / E \cdot F = 1.7 \cdot q \cdot l / v_c \cdot E \cdot F = 1.7 \cdot \eta \cdot I \cdot U \cdot l / v_c \cdot E \cdot F, \quad (2)$$

where F – area of weld cross-section;
 l – length of weld.

The rate 1.7 takes into account the changes of the mechanical and deformation characteristics of the welded materials in the process of MAG welding in dependence on temperature. [4].

Deformation of the weld in the cross-direction Δs_k for low carbon steels can be expressed as:

$$\Delta s_k = (1 \dots 1.4) \alpha \cdot q / c \cdot \gamma \cdot \delta \cdot v_c = (1 \dots 1.4) \alpha \cdot \eta \cdot I \cdot U / c \cdot \gamma \cdot \delta \cdot v_c, \quad (3)$$

where α – coefficient of linear expansion, $cm \cdot ^\circ C^{-1}$;
 γ – rate of heat conductivity, $J \cdot cm^{-1} \cdot s^{-1} \cdot ^\circ C^{-1}$;
 δ – thickness of welded plates, cm;
 c – Specific heat rate.

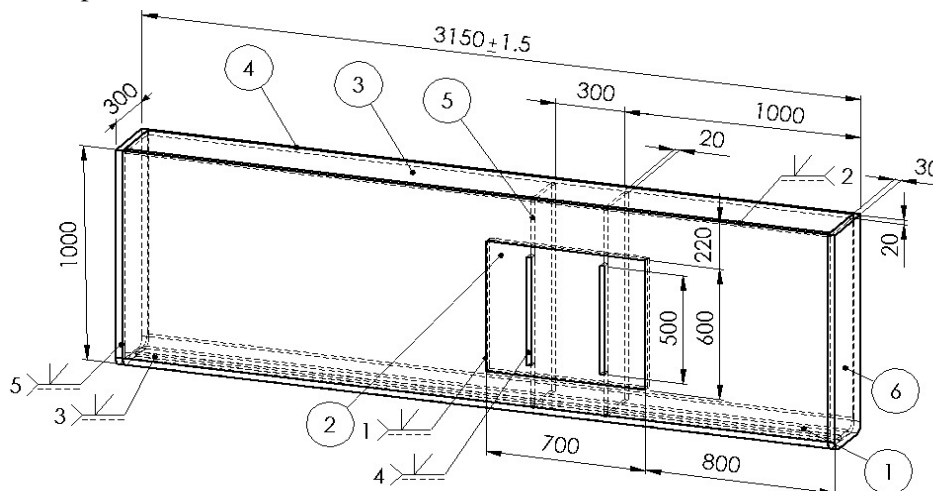

Fig. 1. General view of front crossbeam, numeration of parts and welds

Calculate how in welding process the length of box-shaped beam could change. The beam is welded considered with the quality level B, the concerned standard ISO 5817-2007 from steel sheets S355J2 with medium widths 20 mm. The preparation of the edges of the steel parts for welding in shielding gases goes on the concerned standard EN9692. The total length of the beam L has to be 3150 ± 1.5 mm, as well as the width of the lateral sheets 6 is 30 mm.

The general view of the front crossbeam, numeration of parts and welds is given in Fig.1. The cross-sections of part connection for preparation for welding are given in Fig. 2 and 3.

When the weld No.5 is welded, for forming of root weld, there is the process 136 (EN2254) used, however, for the rest four welds – the process 135. The diameter of the wire 1.2 mm, current for root weld 180...220 A, the other – 280...320 A. Voltage accordingly 22...26 V and 28...32 V. For welding direct current polarity are used. The wire feed speed is $8 \dots 12 \text{ m} \cdot \text{min}^{-1}$, welding speed $100 \dots 200$ and $170 \dots 400 \text{ mm} \cdot \text{min}^{-1}$. Heat input is $0.94 \dots 2.89 \text{ kJ} \cdot \text{mm}^{-1}$.

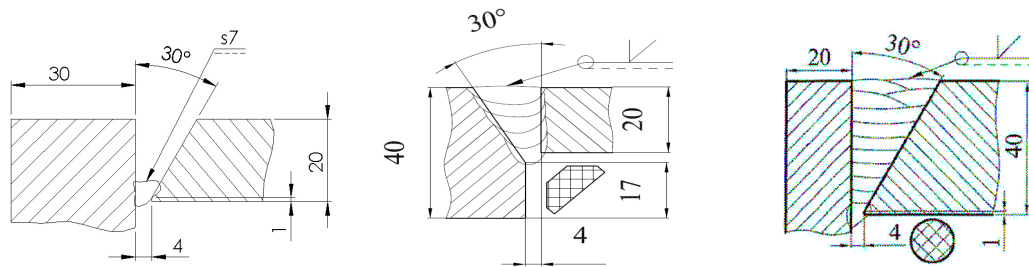

Fig. 2. Cross – weld No5 (left), No 1 (middle), No 4 Chart of cross-section of parts connection (right)

When weld No1 is welded, there is used the process 135. The welded part 2 (with width 40 mm) into the lateral sheet 1, the deformations, caused by shrinkage, acquired – in both: longitudinal and cross wires. The diameter of the wire for making of root weld is 1.2 mm, current for root weld 250...290 A, the other – 360...440 A. Voltage accordingly 26...30 V and 30...34 V. For welding direct current polarity is used. The wire feed speed accordingly is 8...12 and 7...9 m·min⁻¹, the welding speed accordingly 140...360 and 220...500 mm·min⁻¹. Heat input is 1.04...2.99 kJ·mm⁻¹.

When the strength ribs of the construction are welded (weld Nr.4), the process 135 is used. The diameter of the wire for making of root weld is 1.2 mm, for the rest eleven welds -1.6 mm. Current for root weld is 250...290 A, the other – 360...440 A. Voltage accordingly 26...30 V and 30...34 V. For welding direct current polarity is used. The wire feed speed accordingly is 8...12 and 7...9 m·min⁻¹, the welding speed accordingly 140...360 and 220...500 mm·min⁻¹. Heat input is 0.87...2.99 kJ·mm⁻¹.

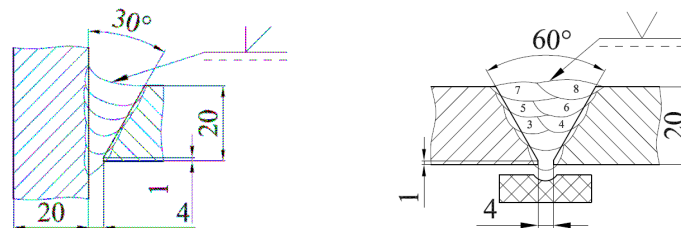

Fig. 3. Longitudinal wire No2 (left) and No3 Chart of cross-section of parts connection (right)

When the weld No2 is welded, there the process 135 is used. The diameter of the wire for making of the weld is 1.2 mm. Current for root weld is 250...290 A, the other four – 280...320 A. Voltage accordingly 22...26 V and 28...32 V. For welding direct current polarity is used. The wire feed speed accordingly is 8...12, the welding speed accordingly 140...360 and 170...400 mm·min⁻¹. Heat input is 0.94...2.89 kJ·mm⁻¹.

When the weld No2 is welded, there the process 135 is used, however, for other seven processes 121 process – welding under flux is used. The diameter of the wire for making of root weld is 1.2 mm, for the rest welds -4 mm. Current for root weld is 260...300 A, the other – 450...680 A. Voltage accordingly 27...30 V and 26...32 V. For welding direct current polarity is used. The wire feed speed for root weld is 8...12, the welding speed accordingly 250...290 and 50 mm·min⁻¹. Heat input accordingly is 1.16...1.73 and 1.40...3.26 kJ·mm⁻¹.

Calculation

For clearing up the dependence of the shrinkage force on the regime of welding, the value of it at minimal (P_{rukmin}), maximal (P_{rukmax}) and medium (P_{rukvid}) recommended parameters for welding of longitudinal welds No.2 is calculated. As parameters in cases of welding root and basic welds are different, at first the shrinkage force for root weld is calculated.

$$P_{rukmin} = 1.7 \cdot \eta \cdot I \cdot U / v_c = 1.7 \cdot 0.85 \cdot 250 \cdot 26 / 0.23 = 40837 \text{ kgf (400363 N)};$$

$$P_{rukmax} = 1.7 \cdot 0.85 \cdot 290 \cdot 30 / 0.6 = 20952 \text{ kgf (205412 N)};$$

$$P_{rukvid} = 1.7 \cdot 0.85 \cdot 270 \cdot 28 / 0.41 = 26644 \text{ kgf (261216 N)}.$$

Calculations demonstrate, that the value of the shrinkage force on regime of welding can change 1.9 times, as well as the smallest shrinkage force is achieved at maximal parameters of the welding regime. In further calculations the shrinkage force will be cleared up at the medium parameters.

The shrinkage force in one layer on basic weld is: $1.7 \cdot 0.85 \cdot 300 \cdot 30 / 0.475 = 27379$ kgf or 268421 N. Basic welds are shaping from four layers, therefore $P_{ruk} = 4 \cdot 268421 = 1073684$ N. The shrinkage force, which occurs in the process of welding of one longitudinal weld No.2 is $1073684 + 61216 = 1334900$ N, as there are two these welds, we come by that the shrinkage force after welding of the welds No.2 is 2669800 N multiplied by the rate 0.98 is 2616404 N.

The shrinkage force, which occurs in the process of welding of longitudinal weld No.3, and consists on seven layers, is calculated the same way – the shrinkage force is 2109527 N. The shrinkage force, which occurs in the process of welding of longitudinal two welds No.4 with the length 700 mm each is 607325 N multiplied by the rate 0.98 is 595178 N.

By calculating of shrinkage forces, resulted from all longitudinal welds, we come by $R_{gkop} = 5321109$ N.

The area of beam cross-section F is $(2.100 + 2.30) \cdot 2 = 520$ cm². Currently deformation of beam Δl is calculated, which appears due to the shrinkage force of longitudinal welds. From expression $\Delta l = P_{ruk} \cdot l / E \cdot F$ the beam deformation is:

$$\Delta l = 5321109 \cdot 315 / 2 \cdot 10^7 \cdot 520 = 0.161 \text{ cm.}$$

The deformations of beam, resulted by welding of cross-directing welds, are calculated by using of expression $\Delta s_k = (1 \dots 1.4) \cdot a \cdot \eta \cdot I \cdot U / c \cdot \gamma \cdot \delta \cdot v_c$,

The shrinkage value R_s for welds No.5, which occurs in the process of welding of root weld is:

$$R_s = 1.2 \cdot 14 \cdot 10^{-6} \cdot 200 \cdot 24 / 0.64 \cdot 7.85 \cdot 2 \cdot 0.25 = 0.0161 \text{ cm.}$$

Shrinkage R_p for root welds 2.-5. is equal:

$$R_p = 1.2 \cdot 14 \cdot 10^{-6} \cdot 300 \cdot 30 / 0.64 \cdot 7.85 \cdot 2 \cdot 0.475 = 0.03168 \text{ cm} \times 4 = 0.1267 \text{ cm.}$$

Total shrinkage from one weld No.5 is 0.1589 cm. As welds are in both ends of the beam, the shrinkage from them R_5 is $0.3178 \text{ cm} \times 0.98 = 0.311 \text{ cm}$.

Shrinkage R_s from root weld of welds No.4 is equal:

$$R_s = 1.2 \cdot 14 \cdot 10^{-6} \cdot 270 \cdot 28 / 0.64 \cdot 7.85 \cdot 4 \cdot 0.415 = 0.0153 \text{ cm.}$$

When basis weld 2, is welded, shrinkage R_p is equal:

$$R_p = 1.2 \cdot 14 \cdot 10^{-6} \cdot 380 \cdot 32 / 0.64 \cdot 7.85 \cdot 4 \cdot 0.6 = 0.0170 \text{ cm.}$$

When basis weld 3.-12., is welded, shrinkage R_p is equal:

$$R_p = 1.2 \cdot 14 \cdot 10^{-6} \cdot 420 \cdot 32 / 0.64 \cdot 7.85 \cdot 4 \cdot 0.62 = 0.0182 \text{ cm} \times 10 = 0.182 \text{ cm.}$$

Total shrinkage from one weld No.4 is 0.2145cm. As welds are two, the total shrinkage R_4 : $0.429 \text{ cm} \times 0.94$ is 0.403 cm.

The total deformations R_{kop} , resulted by welding of cross-directing welds No. 4 and No. 5 we get by summarizing:

$$R_{kop} = R_4 + R_5 = 0.311 + 0.403 = 0.714 \text{ cm} = 7.14 \text{ mm.}$$

Due to the shrinkage force in longitudinal welds the length of the beam decreases for 0.161 cm (1.61 mm).

Parts 1 and 2 are welded with weld No.1 before they are inserted into jig, where assembling starts, due to shrinkages, acquired in the welding process, only the length of the part 1 is affected and does not have any impact on the total value of beam deformation.

When the vertical components of weld No.1 are welded, shrinkage R_s , when root weld is welded is:

$$R_s = 1.2 \cdot 14 \cdot 10^{-6} \cdot 270 \cdot 28 / 0.64 \cdot 7.85 \cdot 3 \cdot 0.415 = 0.0204 \text{ cm.}$$

When basis weld 2 is welded, shrinkage R_p is equal

$$R_p = 1.2 \cdot 14 \cdot 10^{-6} \cdot 380 \cdot 32 / 0.64 \cdot 7.85 \cdot 3 \cdot 0.6 = 0.0227 \text{ cm.}$$

When basis welds 3-5., are welded, shrinkage R_p is equal:

$$R_p = 1.2 \cdot 14 \cdot 10^{-6} \cdot 420 \cdot 32 / 0.64 \cdot 7.85 \cdot 3 \cdot 0.62 = 0.0243 \text{ cm} \times 3 = 0.0729 \text{ cm.}$$

Total shrinkage from one weld Nr.4 is 0.116 cm, as welds are two, the total shrinkage is 0.232 cm. As to the length of the welds is only 50 % from the vertical size of the beam – the estimated contraction of part 1 is approximately equal: $2.32 \times 0.5 = 1.16 \text{ mm} \times 0.96$ is 1.14 mm.

The total deformations Δkop , resulted by welding of longitudinal and cross-directing welds as well as by using of medium rate of welding regimes are $\Delta kop = 1.61 + 7.14 + 1.14 = 9.89 \text{ mm}$. This calculation result means, that the length of part 1 before welding has to be for 10 mm longer, than without load, respectively $(3150 - 2.30 - 2.4) + 10 = 3092 \pm 1.5 \text{ mm}$.

Experimental results

There were 30 analogical boxes made – shape beams by using of MAG welding technology, from the parts with dimensions, weld preparation methods and welding regimes, as it was mentioned above. The length of the side plates was $3090 \pm 0.5 \text{ mm}$. Mean of the length of the beams was 3149.578 mm, area of dispersions $\omega = 4.80 \text{ mm}$, minimal and maximal length of the beam – accordingly 3147.0 mm and 3151.8 mm. As defective 14 beams were rejected, in five from these the length exceed the demanded size, as well as nine beams were shorter than the size demanded $3150 \pm 1.5 \text{ mm}$.

Analyses of the results

As summarizing deformations from cross – directing deformation and longitudinal shrinkage we cleared up that after welding of the beam the length of it shortened for approximately 9.89 mm, it means, that sizes of parts 1 and 4 have to be bigger for 9 – 10 mm, then it is due to the standard EN9692 for providing of the width of the chink 4 mm (see Fig. 2)

This result was achieved in conditions, that the welder uses medium regimes and medium welding speeds. As calculations for change of the shrinkage force in dependence on the welding regime and welding speed (if marginal values are chosen) demonstrate, the shrinkage force and therefore deformation also can change for almost twice.

If to decrease the number of layers in the weld, increasing the width of the layer as well as to decrease the welding speed, the shrinkage force increases more greatly. The deformations of cross-directing welds increase, if the current intensity is increased and welding speed decreased.

Conclusions

1. The changes of technology of the welding process in allowable limits of the parameters cause deformations, which exceed the limits of the sizes demanded.
2. If medium parameters of the regime of welding are chosen, it is possible to make the beam in the demanded limits of the size.
3. The shrinkage force, when longitudinal welds are welded, most substantially depends on the welding speed and number of layers in the weld.
4. Cross – directing deformations depend on the welding speed, voltage and number of layers in the weld.

References

1. M.Audronis, J.Bendikas. The Welding Deformations of Chrome-nickel Stainless Steels. Materials Science. Vol. 9, No2, 2003.
2. Žmindak M., Melicher R., Novak P. Numerical simulation of thermal process in welding/6th International Scientific Conference “Engineering for rural development”, Jelgava, LUA, May 24-25, 2007, publ. LUA, pp.221-225.
3. Vinokurov, V.A., Grigorianc, A. G. Theory of Welding Deformations and Stresses. Moscow, Mechanical Engineering, 1984: 280 p. (in Russian).
4. Vinokurov V.A. Welding Deformations and Stresses. Moscow, Mechanical Engineering, 1968: 236 p. (in Russian).