

THEORY AND METHODS OF MAINTENANCE OF HIGH EFFICIENCY USES OF ENERGY BY INDUSTRIAL CONSUMERS

Toivo Kabanen¹, Valeri Karpov², Andres Annuk³

¹Tallinn University of Technology Tartu College, Estonia; ²Saint-Petersburg State Agrarian University, Russia; ³Estonian University of Life Sciences, Estonia
toivokabanen@hotmail.ee

Abstract. The offered theory of power savings is based on theorems and methods of certain integration, on possibility of measurement and registration of energy and capacity on all elements of the scheme and allows not only to estimate distribution of superfluous losses in the consumer system, but also to define the contribution of each process to power consumption of production. Under the specified theory and settlement methods the first variants of information-measuring system (IMS) for carrying out of energy audits in consumer systems and decision-making under power savings are created. The analytical method of definition of influence of increase of power efficiency on economics manufacture indicators is offered. The concept of own profitableness of the energy growing at power savings with advancing of growth of the general profitableness is entered. The specified concept of power resources of the agricultural enterprise, including local values of energy of renewing sources (ERS) which should be defined by special measurements is offered. The requirement about reduction of the consumer system in a condition of the maximum power savings before use of resource ERS is formulated. Such point of view is essentially supported by that the stated material should be added by the account of influence on indicators of a power system of biological objects (animals, birds, and plants). The conclusion that universality of power schemes of the enterprises and information-measuring systems for their power audit does the developed method of increase of power efficiency suitable for any scales of manufacture is obvious.

Keywords: energy efficiency, economic effectiveness, method of finite relations regards.

Introduction

The requirement for increasing energy efficiency resulted in the redefinition of the term "industrial energy consumption". The first stage of energy supply production covers the selection of energy-generating equipment, i.e., the determination of its rated capacity depending on the maximum expected capacity. This is the stage at which the preparation of energy engineering specialists at a higher education facility essentially ended in the recent past as the choice of equipment was to solve a certain issue: a reliable energy supply for mechanisms and processes. As far as the substantial content is concerned, ensuring energy efficiency is the next stage of energy supply technically aided by the adopted equipment and the entire infrastructure which determine the overall diversity (including the physical and chemical characteristics and efficiency) of energy processes determined by the common goal and production technique. Taking all of the above into consideration, the problem of increasing energy efficiency should be defined as a complex one, which encompasses an analysis of all energy processes, justification of adequate efficiency criteria, study of the relationships that have an effect on the actual value of the above criteria, and the development of particular and general methods of increasing efficiency.

The above-mentioned approach to the development of the equipment placement scheme has been implemented in [1] means of introducing the concept of a consumer energy system (CES) provided as an energy scheme in (Fig. 1).

The main difference between the above scheme and the equipment placement scheme lies in the representation of three types of energy technology processes (ETP) in the former: 1 – main (production) processes that result in products; 2 – auxiliary processes that result in an intermediate outcome in terms of production; 3 – energy processes providing the necessary living environment (heating, lighting, ventilation). The introduction of the ETP into the scheme means that energy processes have become the main object of analysis. Not only do the ETP determine the type of energy necessary for production, but they also establish the minimum amount thereof necessary for the production of the specified product amount P (as a particular case of ETP) in accordance with the $Q_{min} = Q_{spec}P$ formula, where the specific consumption Q_{spec} per one unit of the result of each ETP is known. The analysis of the energy efficiency of a functioning CES essentially begins with the determination of the above specific consumption value. The scheme allows the structural hierarchy of the system (element, line, ETP) to be taken into consideration in the course of the analysis, which

ensures the systematic targeting of the efficiency of energy processes over the course of the analysis. Moreover, the CES falls into two zones as far as the nature of energy processes is concerned: energy transfer (comprised of the lines supplying energy to the ETP) and energy use (the ETP as such).

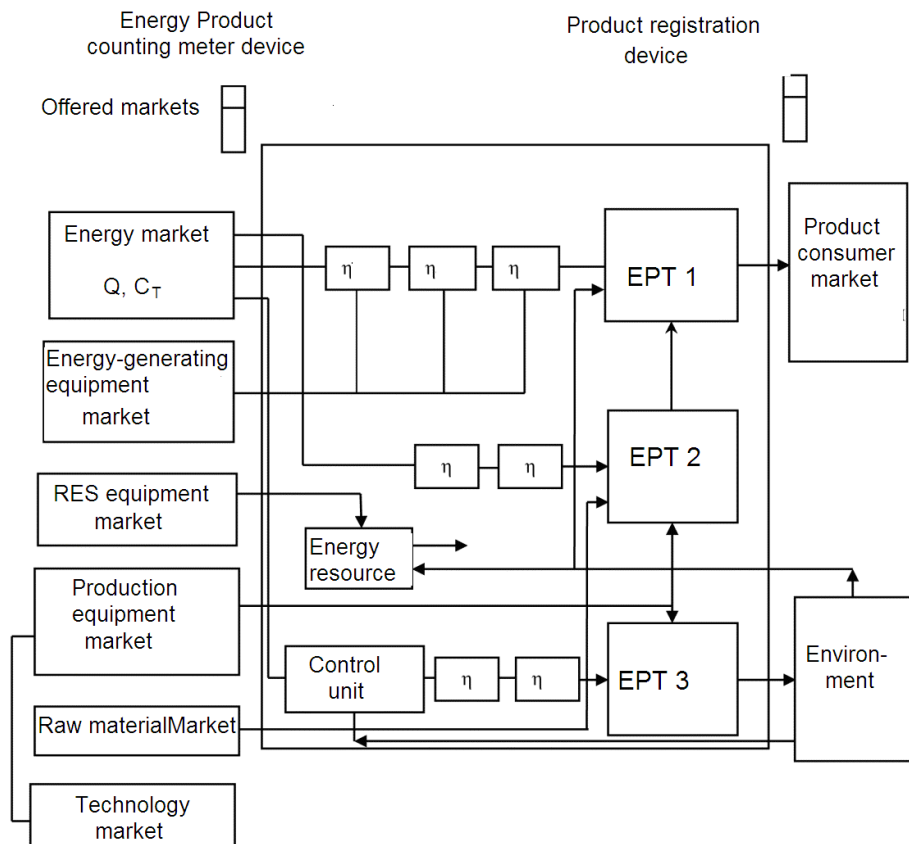

Fig. 1. Energy scheme of the CES

A standard $Q_P = Q/P$ energy efficiency indicator for ETP 1 of the second zone is expressed as the energy intensity of the product (as the sub-product). The same indicator characterises the energy efficiency of the whole system. As the result, the concept R has been established for the ETP and the product is a particular case thereof; the energy intensity of the result $Q_R = Q/R$ can also be regarded as the general energy efficiency indicator for any ETP. The use of the relative energy intensity $Q_E = Q_S/Q_F$, which equals the ratio of the energy supplied to the element to the energy at the final stage, is justified as the indicator of the energy efficiency of the process for elements and energy transfer lines in [1]. The same source shows that the relative energy intensity is linearly connected with the energy intensity of a product by means of the $Q_P = Q_{Spec}Q_E$ formula, which allows the analysis and efficiency management methods to be standardised for the whole consumer system. This places additional emphasis on the consistency of the CES as a module consistent for any scale of industrial energy consumption. However, the necessity to minimise the energy intensity of the product in practice requires a method targeted at bringing the actual value of the former to the probable minimum to be developed. In the method developed and presented in [1], such values are the already mentioned specific energy per unit of an ETP zone and the relative energy intensity for the nominal or assumed rated load of technical elements in the zone of energy supply to the ETP. As the energy intensity of processes under various conditions depends on the energy transfer capacity of the element or the environment, one must be aware of such relationships or determine them in the course of an energy audit in order to manage efficiency. An important condition for the functioning of the CES is the market represented as two components in the figure: the offered market that supplies the production with energy, equipment, technologies, raw materials and other components in exchange for money and the consumer market where products are sold and cash expenses are returned. It must be specifically noted that the increasing of energy efficiency is a market-imposed requirement that ensures that the competitiveness of the product increases. The fact that market conditions were taken into

consideration allowed the concept of “specific energy profitability” [2] to be justified as well as energy efficiency and the improvement of economic indicators to be connected; it also served as the basis for this type of activity to be regarded as trans-occupational and for including successful energy efficiency specialists into management personnel.

Materials and methods

The lack of an opportunity to describe the change of capacity in due time in simple functions (i.e., inability to integrate) did not allow the mathematical optimisation theory to be used for the solution of practical energy efficiency problems in the CES.

The theoretical justification of the practical energy efficiency technique is based on the measurability of energy indicators (energy Q and capacity P); the recognition of energy in the CES as a substance characterised by volume, capacity as the partial derivative of energy in one volume section, and the opportunity for a transition to the complete representation of the energy movement process dynamics by means of the ratio of capacities in two sections of the cylindrical element. The finite ratio method (FRM) developed on the basis of the above assumptions has been confirmed by the algebraic transformation of the conservation law and the derivative expression for relative energy intensity, which allowed the conditions for the consistency of energy intensity to be achieved and the principle of controlling this indicator in the CES to be established [3]. The second component of the energy efficiency theory lies in the proof that the registered energy curve $Q = f(t)$ can be used as a source of information about the energy process. The analysis methods and conclusions are fully based on the stipulations and theorems of definite integrating and, in combination with the FRM, allow the energy intensity of processes to be controlled. The concept of the element energy characteristic in the form of the ratio of finite capacities $P_S = f(P_F)$ has been established in this line of research and the method for controlling the simultaneity of the change in the final parameters of the process has been suggested. The method of using the linear disintegration of the energy curve $Q(t)$ on the basis of Lagrange’s theorem and the theorem on differential inequalities in definite integrating by S. A. Chaplygin, which allowed solving the problems of increasing the energy efficiency of the registered energy processes, is specified.

Results and discussions

To test the developed methods in actual work, information and measuring system (IMS) was created on the basis of a 16-channel electronic recorder with memory blocks, interfaces and standard software. Tests have shown that special software must be developed in order to control and manage the energy efficiency of the CES to support the following functions of the production module:

- measuring and registering energy and other physical parameters of elements and the ETP;
- analysis of the efficiency of processes in the equipment and the ETP, taking the resulting functions into consideration;
- analysis of the system conformity to the regulatory requirements valid for the ETP, equipment and infrastructure;
- analysis of the timeliness of energy-using equipment that switches on and off;
- determination and analysis of the enterprise efficiency as a whole;
- maintenance of the database containing information about the equipment, technology, and regulatory requirements;
- maintenance of the database containing local information about climatic parameters and the state of unconventional energy sources;
- maintenance of the legal reference system for energy consumers;
- energy service management of energy efficiency by means of the IMS component comparable to a control room; the functions of the component must be established;
- internet search engine functions;
- functions of logistics systems in energy consumption:
 - input logistics (energy consumption management, operations involving technologies, equipment and raw materials);

- output logistics (analysis and management of energy distribution by product types and by ETPs).

However, even the standard software of the electronic recorder manufactured by the plant Vibrator allowed the actual energy intensity of milk production in several farms and the processes that contribute to energy intensity the most to be determined in the course of tests. The above research is the first stage in work done to increase energy efficiency and its success proves that the developed methods are applicable in practice. The use of the IMS on the basis of the electronic recorder on the brake dynamometer tester for electric motors allowed the energy characteristic of the electric motor to be specified and the method for the experimental diagnostics of equipment by energy efficiency indicators to be suggested.

The above material about the technical and process-related content of the CES may be regarded as the basis for obtaining information about energy efficiency in any enterprise. To be used in agribusiness enterprises, it must be supplemented with specific characteristics of the production in the sector. First and foremost, it is the production of foodstuff that results in products that contain biological energy. And agribusiness enterprises normally possess land, the condition of which determines the volume of the produce to be harvested, the local RES, fuel (energy resource) consumption of mobile power processes and the preconditions for the territorial segregation of products. Biological products (plants, livestock, poultry, and biological technologies) are of crucial importance since they:

- can be regarded as biological ETPs producing initial food produce;
- determine technological cycles;
- determine the type and amount of energy supplied to them (for instance, high-quality electromagnetic energy for plants and feed for livestock);
- determine the volume of the produced products by means of their productivity, i.e., introduce the second indicator (alongside energy) of the intensity of production energy;
- determine the availability of biological production waste and secondary biological energy resources.

A crucial characteristic that sets the energy engineering in agribusiness apart from industrial energy engineering is also the close link between the social issues of rural areas and the level of efficiency related to the energy supply and production energy. The fact is that the availability of power needed for energy in agribusiness is low and the annual energy consumption per one rural resident is much lower than per one urban resident, which, in turn, results in industrial, social and household-related discomfort as well as the migration of rural population. This is why the energy efficiency issue must be solved simultaneously with social problems, and the solution must be accompanied by the overall increase in energy consumption while the efficiency of its use in production increases. The above peculiarities do not allow the techniques of industrial energy efficiency to be simply transferred to agriculture. On the contrary, they suggest that the energy engineering of agribusiness should be distinguished as a separate component of general energy engineering with special techniques and personnel training.

Conclusions

The necessity of the development of the modern organisational form providing services to rural energy consumers in the market environment is beyond doubt. Such a form must be based on the creation of companies capable of using the contemporary information technology, software and qualified specialists for the constant monitoring of energy efficiency in several objects and enterprises simultaneously, developing measures to increase energy efficiency by implementing the latest scientific and technological achievements in equipment and energy use processes, and applying them to the above projects. The research has determined that the decrease in the intensity of product energy increases the profitability of energy use and of the whole enterprise. This result transforms energy engineering management into the management of an enterprise economics, i.e., production management. It must also be noted that the scale of the described activity based on the modular representation of consumer systems is not limited in terms of objects or areas, which gives grounds for the establishment of a new modern system of providing services to rural energy consumers. The

novelty of the developed technique and the design solutions has been proven by patents issued in the Russian Federation; thus the system created on the basis thereof is innovative to a considerable extent.

References

1. Karpov, V. & Yuldashev Z. Energy Efficiency. Finite Ratio Method. St. Petersburg: St. Petersburg's State University of Agriculture, 2010. 147 p. (in Russian).
2. Karpov, V., Gushchinski A. & et al. Finite Ratio Method in Energy Efficiency Theory and Consumer Energy System Management. "Energy Efficiency, Implementation of Electrical Equipment and Production Process Automation in Agribusiness": collection of scientific papers. Saint Petersburg: St. Petersburg's State University of Agriculture, 2001. pp. 16-35. (in Russian)
3. Kabanen T. & Karpov V. As an Addition to the Structural Theory of Optimizing Energy Efficiency in Consumer Systems. "Agronomy Research 2011", 2011. Ed by R. Lillak, pp. 77-83.