

## THERMOELECTRIC GENERATORS AS ALTERNATE ENERGY SOURCE IN HEATING SYSTEMS

Martins Ozollapins, Aivars Kakitis  
Latvia University of Agriculture  
m-ozollapins@inbox.lv, aivars.kakitis@llu.lv

**Abstract.** By using thermoelectric generators it is possible to develop independent electric energy source in burning and heating systems – in households and industrial heating. With this energy source it is possible to provide with electricity systems appliances, lightening and other consumers. Potential placements for generators are on furnace walls, on flue way walls, on flue pipe walls after furnace. Generators can improve efficiency of combustion, because there is amount of waste heat that leaves through flue pipe in burning process. There are no boundaries for combining elements in system as just the space for their placement. As more elements are linked in chain, as much electric energy is produced. This is one of methods to develop a cogeneration process in domestic boiler house or industrial heating, or burning systems. In research thermoelectric element current, voltage, power and efficiency are defined in different temperature differences.

**Keywords:** thermoelectric effect, Seebeck effect, thermoelectric generator, TEG.

### Introduction

Biomass burners and firewood furnaces are used in domestic and industrial heating and burning processes. Many of these systems require electric energy support for full performance. By applying thermoelectric generators to these heat sources it is possible to develop independent electric energy source, which start generation in the moment when there will be temperature difference on their sides. Thermoelectric generators are devices that use Seebeck effect – converting heat (temperature differences) directly into electrical energy. As the heat flows from hot side to cold side, free charge carriers – electrons or holes – in the material are also driven to the cold end. The resulting voltage is proportional to the temperature difference via the Seebeck coefficient. The thermoelectric generator will generate DC electricity as long as there is a temperature difference across the module. The more electricity will be generated when the temperature difference across the module increases, and the efficiency of converting heat energy into electric energy will also increase.

### Materials and methods

For research two thermoelectric generators TEP1-1264-1.5 were used (Fig. 1). One generator is a module consisting of 126 Bi<sub>2</sub>Te<sub>3</sub> p-type and n-type semi-conductor couples. By connecting an electron conducting (n-type) and hole conducting (p-type) material in series, a net voltage is produced that can be driven through a load. Modules surface is flat plane with dimensions 40x40 mm and height 3.5 mm. Maximum working temperature on hot side is 280 °C continuously and 380 °C intermittently. For cold side it can't be more than 180 °C. Heat flux across one module is about 140 W [1].

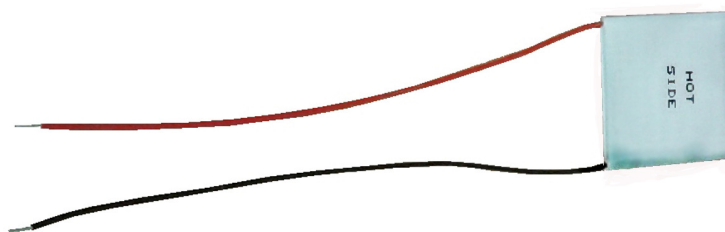

Fig. 1. Thermoelectric module TEP1-1264-1.5

For research experimental system (Fig. 2) was developed, consisting of thermoelectric generators 4, heat source – heater 1 with aluminum heat diffuser 2, heat sink 5, water supply 6, insulation 3. Cooling side is a specially made aluminum heat sink with internal water circulation as a heat carrier. Water flow in heat sink was 0.0127 kg·s<sup>-1</sup>.

For better heat transfer both sides of generators were with thermo-paste covered. As module producer requires for better electricity generation modules have to be under pressure of 137.50 kg·cm<sup>-2</sup>, because of that bolt fastening 7 was applied [2].

Maximal temperature achieved on generators hot side with experimental system was 297 °C, with temperature difference 267 °C. Temperature on hot side was kept and adjusted with temperature regulator 9 and meanwhile necessary parameters were recorded. Values of temperature were determined with thermo-couples. Measurements were recorded with computer program PICO Recorder, afterwards data were processed in MS Excel and resulting graphs were developed.

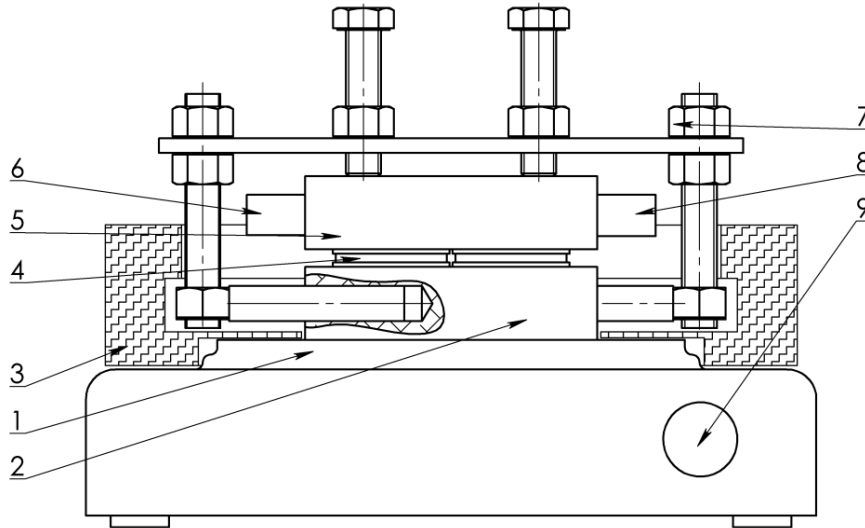

Fig. 2. **Experimental device:** 1 – heater; 2 – aluminum heat diffuser; 3 – heat insulation; 4 – thermoelectric generators; 5 – heat sink; 6 – heat carrier (water) inlet; 7 – device fastening; 8 – heat carrier (water) outlet; 9 – temperature regulator

### Results and discussion

Results of research are elaborated in graphs. Generated amount of electricity increases linearly with rise of temperature difference on module sides (Fig. 3). Offsets may be a cause of unsteady temperature at measuring moments.

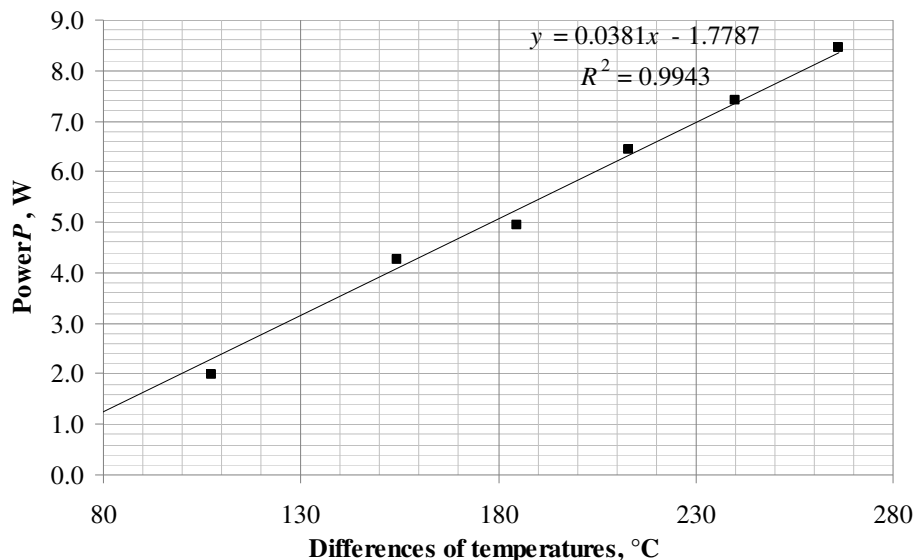

Fig. 3. **Power of one TEG module depending on difference of temperatures**

In research 8 maximal power values were determined in 8 different temperature differences on module sides. Maximal generated power was at highest temperature difference 267.0 °C and gained 8.46 W per module (Fig. 4).

Most important electric energy consumer in heating system usually is circulation pump, which ensures circulation of heat carrier. Pumps switching off because of power cut off can be hazardous to

whole system and even humans nearby. Therefore it is necessary to ensure independent electric energy support for pump, which isn't effected from outside weather and etc. Power of most used domestic central heating circulation pumps varies between 25 – 90 W and is dependent of whole system [3]. By applying thermoelectric generators in furnace and providing temperature difference at least 267.0 °C, it is possible to calculate approximate minimal number of modules (1).

$$n = \frac{P_1}{P_2} \tag{1}$$

where  $n$  – approximate number of necessary modules;  
 $P_1$  – necessary power for circulation pump, W;  
 $P_2$  – generated power with one module, W.

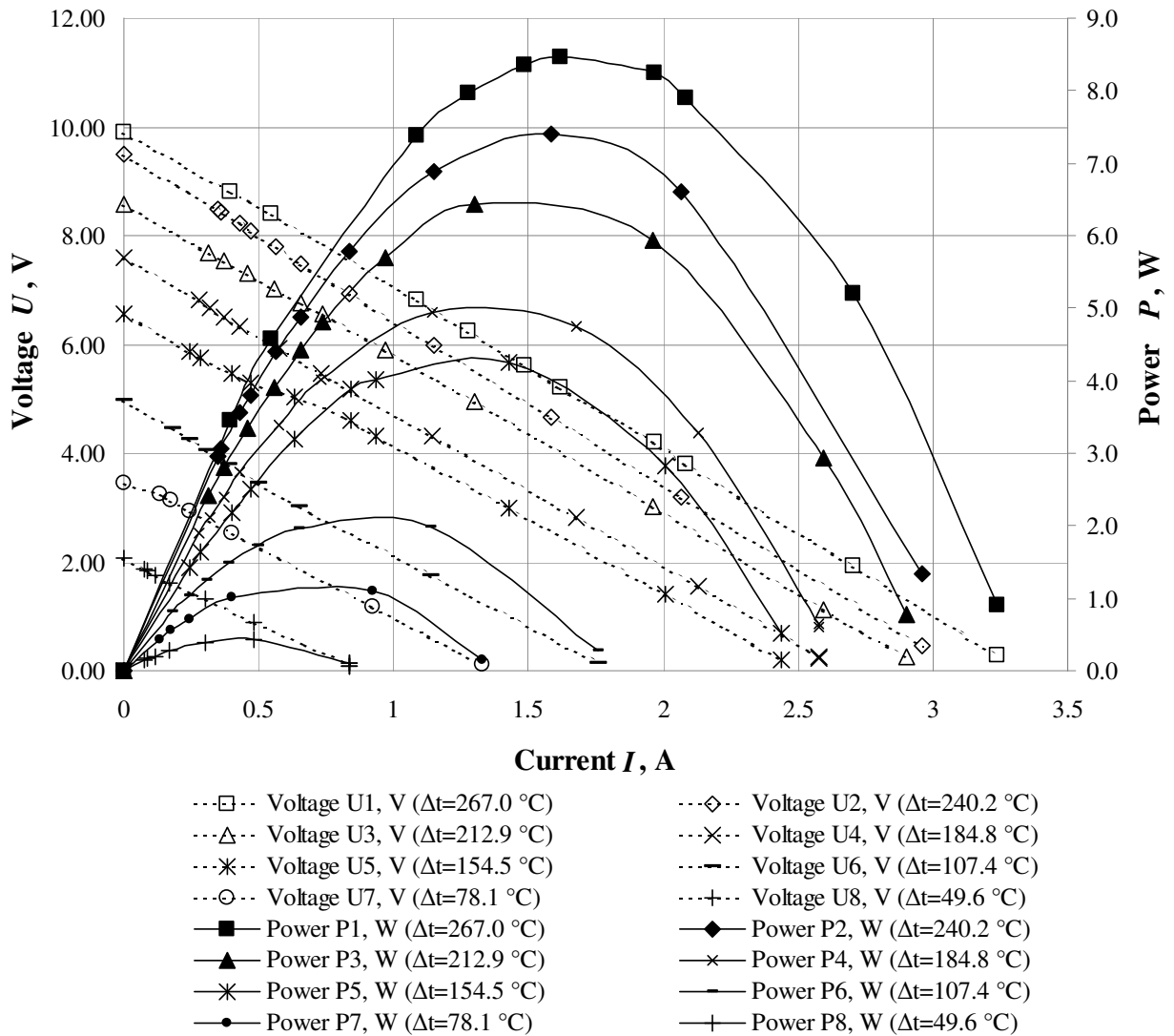

Fig. 4. Voltage and power values of one TEG module depending on current and difference of temperature

Necessary number of modules is in range from 3 to 12 pieces, with generated power from 25.4 to 101.5 W. Number of applied modules is highly dependent from module placement. Before applying modules it is necessary to measure temperatures in furnace or flue pipe to model thermoelectric generator. Some safety coefficients for power guaranteeing from measurements and modeling can be used in final calculation of generator.

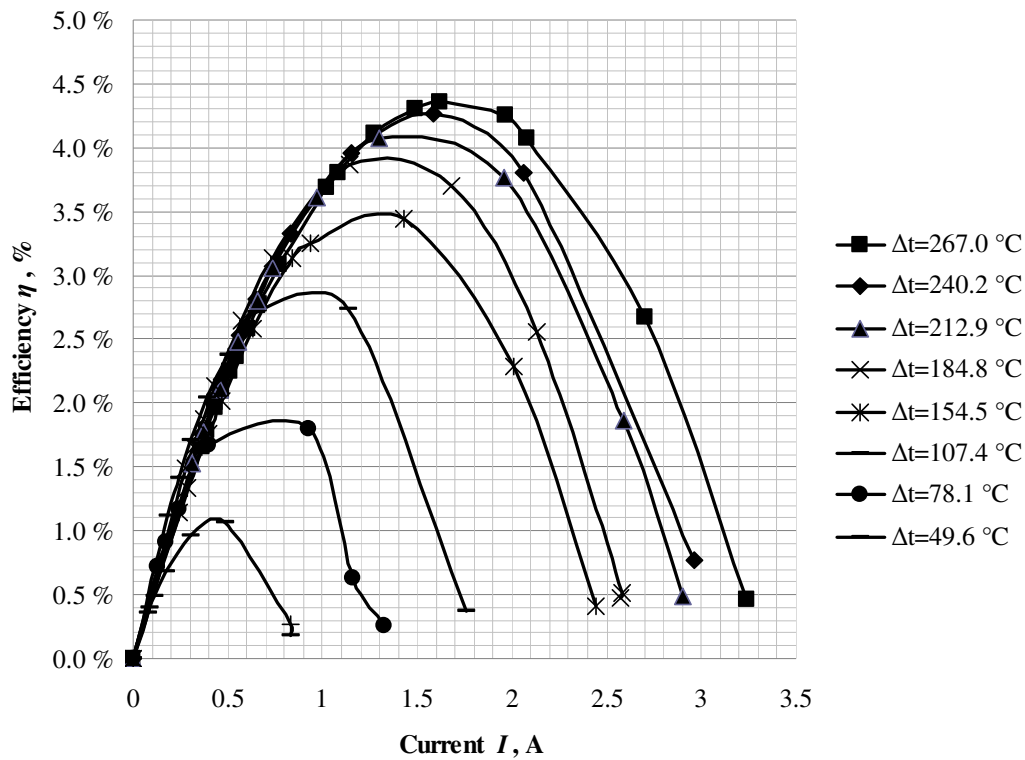

Fig. 5. Efficiency of two modules

Efficiency of thermoelectric generators is increasing and stabilizing with temperature difference and reaches 4.36 % at  $\Delta t = 267.0\text{ }^\circ\text{C}$  (Fig. 5 and Fig. 6). If in system heated up water is necessary, then efficiency of whole heating or burning system will have higher value, than just thermoelectric generators.

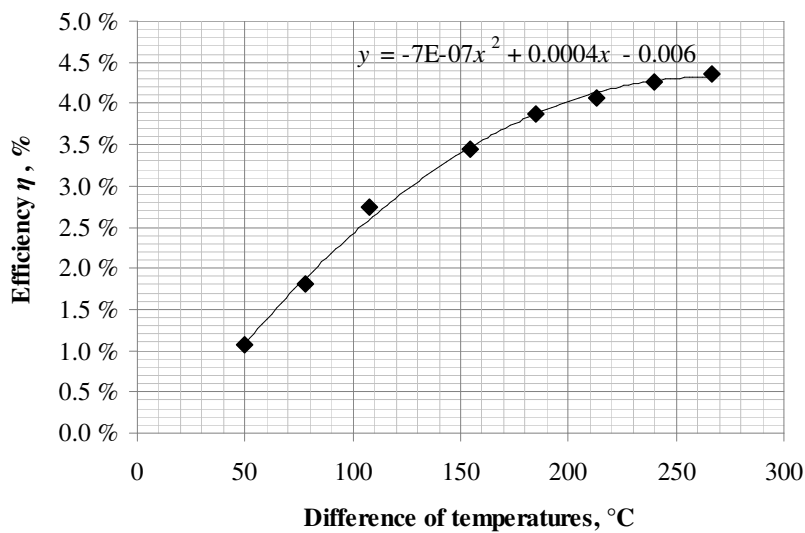

Fig. 6. Efficiency depending on difference of temperatures

**Conclusions**

1. With current experimental system maximal generated power of thermoelectric module TEP1-1264-1.5 at temperature difference  $267.0\text{ }^\circ\text{C}$  reaches 8.46 W per module.
2. Open circuit voltage for one module at temperature difference  $267.0\text{ }^\circ\text{C}$  in current system is 19.8 V.
3. Efficiency of two thermoelectric modules in experimental system reaches 4.36 % at highest temperature.

4. By combining modules in heating or burning systems it is possible to develop independent alternate electric energy source, which would be sufficient to supply consumers with electric energy.
5. Before applying modules, it is necessary to measure temperature range in specific furnace or flue pipe, because of power high dependence on temperature difference.

### **Acknowledgments**

This publication has been prepared within the framework of the ERAF Project “Development of mechanization equipment for energy crops conditioning”, contract No. 2010/0306/2DP/2.1.1.1.0/10/APIA/VIAA/128.

### **References**

1. Thermoelectric modules. [online] [17.02.2012]. Available at: <http://www.termogen.com/pages/modules.html>
2. Power module installation notes. 5p. [online] [13.12.2012]. Available at: [http://www.thermonamic.com/Power\\_Module\\_Installatio.pdf](http://www.thermonamic.com/Power_Module_Installatio.pdf)
3. Cirkulācijas sūkņi. [online] [20.02.2012]. (In Latvian). Available at: <http://www.siltumnieks.lv/pub/pub.catalogue.php?cat=52>