

TENSILE STRENGTH OF HOP TRAINING WIRES AND THEIR ATTACHMENTS

Lubomir Vent, Adolf Rybka, Petr Hermanek, Ivo Honzik, Bohuslav Jost, Jiri Masek
Czech University of Life Sciences Prague
lvent@tf.czu.cz

Abstract. One of the risky places, that can influence the final purity of the final product in hop growing, is the way of hop strings hanging on the trellis supporting wire. The ideal state is when the hop-field supporting wires stay clean and without any attachments after the hopvines had been pulled down. The article deals with different variants of hop strings hanging and measurement of the pulling force itself at a field test. Two-year results of field tests proved advantageousness of the hop string hanging variant in combination of a black annealed wire of 1.06 mm in diameter with a polypropylene twine of strength labelled as 12 500 in the form of a simple attachment, as well as variants combining the same wire and a jute twine labelled 2200x2 in the form of a double attachment. Other variants using attachments made of jute or sisal are unsuitable due to a large number of fallen hopvines in the vegetation period.

Keywords: pulling down, hops, wire, twine.

Introduction

At hop production, the purity of the final product is one of the priority indicators of hop processing quality ensured by the grower. Nowadays, hop training wires are hung on the ceiling of wirework by means of attachments made of polypropylene twine. Old parts of these twines contaminate hop products [1]. One of the solutions is to find a twine with ideal tensile strength which breaks before the wire. In this case there will be no parts of twines on the ceiling of the wirework [2]. It is possible to search for other hanging solutions which would substitute the polypropylene twine. Such a step would contribute to reduction of contamination of hops intended for further processing.

Materials and Methods

The research dealing with different variants of hop string hanging was carried out for the second year in a row in a hop field. In 2010 we tested combinations of various strengths and versions of attachments made of polypropylene twine (simple and double attachments) [3]. In 2011 the experiment was further extended by another combination variant of wires with different strength and twines of different materials. Besides hop-string hanging by means of twines, some other hanging variants were tested without using twines [4]. The field experiment monitored strength relations between a guide wire (hop string) and its attachment. In the course of the experiment, during the hopvine harvest the measurement of the strength of the wires and twines was carried out. The field experiment included twenty-eight combinations of hop-string attachments to the hop field supporting wire. For measurements we use a black annealed wire with diameter of 0.90, 1.06, 1.20, 1.30, 1.40 mm, polypropylene twine 11 000, 12 500, 17 000 dTex (JUTA Plc.), jute twine 1700x2, 1700x3, 2200x2 (JUTA Plc.), sisal twine 2000, 3300 (JUTA Plc.), hemp twine 323 N (JUTA Plc.), paper twine (Textilose – France) of 4.20 mm in diameter. With the twine attachments two versions were tested – the so called simple and double attachment (Fig. 1). Steel galvanized staples of VR22 ZN type were also used to attach the hopstrings. The stapling was done by stapling plier type FL 222/LIG 122 (Fig. 1).

Stapling was fully convenient for the technological procedure of hopstrings hanging. Another specially tested variant was hanging a hopstring on an attachment made of steel wire and attached beforehand. Such an attachment may be fixed to the supporting wire of a hop field already at its foundation and can stay there for the rest of its life.

The field experiment focused on detection of any hopvines fallen spontaneously down during the vegetation period before pulling down, measuring the breaking force of a hopstring (or perhaps an attachment) at pulling down the hopvines, detection of the breaking point at pulling down the vines (with wire or twine).

To measure the breaking force of a hopstring or an attachment, equipment depicted in Fig. 2 was assembled. It consists of a tractor with a trailer which was supplemented with a frame for swing

anchorage of the tensile sensor. The other side of the sensor was prolonged by the trailer to catch hopvines when pulled down.

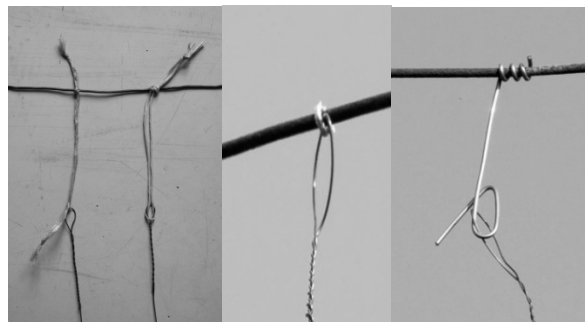

Fig. 1. **Special attachments:** Left – single and double attachments; middle – steel galvanized staple attachment; right – steel wire attachment

The both, the spot of vine attachment at pulling down and the vine angle at pulling down were kept. The swing placement of both ends of the tensile force sensors ensured that at pulling down only the axial force in the hopstring was measured. To measure the force itself we used a tensile force sensor supplied by HBM Brno company (exclusive representation by Hottinger Baldwin Messtechnik GmbH) with type designation U9B and measuring range 0-1kN.

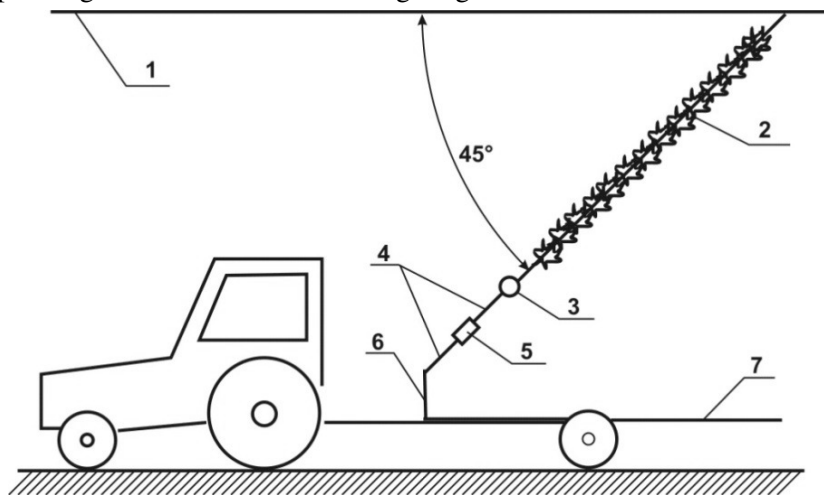

Fig. 2. **Schematic description of equipment measuring the force at hopvines pulling down:**

- 1 – supporting wire of hop-field trellis; 2 – hopvine on hop string; 3 – loop to attach hopvine to tensile force sensor; 4 – swing arms of the sensor; 5 – tensile force sensor;
- 6 – frame to attach sensor arm; 7 – semi-trailer

The sensor output signal was further processed by means of MGC plus, a mobile central measuring station also supplied by HBM company and connected to a laptop. The central measuring station, sensor, and the measured data storage were secured by Catman Easy program, which is provided with the station. After the whole measuring system had been installed, control of the sensor calibration was done by means of a hanger with the weight of 30 kg [5]. We cut the twines off at the height of app. 0.8 m above the ground and passed the vines through the loop on the sensor arm. Then the vines were stretched at an angle of 45° by a tractor travelling with a trailer (Fig. 4) and pulled down on the trailer. The tensile force was recorded at a time frequency of 50 Hz in the course of pulling one whole row of vines down. During pulling down we recorded each pulled vine if the hopstring or attachment had broken.

Results and Discussion

For purposes of the measurement all of the variants of a hopstring or attachment had been chosen, and from the remaining rows that had not been harvested samples of hopstrings and attachments had been taken for following laboratory measuring. The resulting values are to be found in Table 1.

Table 1

Field measurement results
(J – simple attachment, D – double attachment, PP – polypropylene)

Variant number	Description	Wire, mm	Attachment type	Fallen vines, ks	Average value of breaking force, N	Standard deviation, N	Variation coefficient, %	Break point hopstring – wire, %	Break point attachment, %
1	staple	1.06	staple	-	329	41.6	12.6	100	0
2	staple	0.90	staple	-	271	29.6	10.9	100	0
3	check	1.06	PP 12500D	Record mistake of central measuring station					
4	check	1.06	PP 12500J	-	329	78.8	23.9	0	100
5	wire+twine	0.90	paper 4,20 J	Measured value – same variant as ad/ 6					
6	wire+twine	0.90	paper 4,20 J	-	302	55.5	18.4	100	0
7	wire on wire	1.20	-	-	455	47.3	10.4	100	0
8	wire+twine	0.90	PP 12500J	-	245	46.7	19.1	7	93
9	wire+twine	0.90	PP 12500J	Measured value – same variant as ad/ 8					
10	wire on wire	1.30	-	-	641	30.4	4.7	100	0
11	wire+twine	0.90	PP 12500 D	Measured value – same variant as ad/ 12					
12	wire+twine	0.90	PP 12500 D	-	303	48.8	16.1	100	0
13	wire on wire	1.40	-	-	636	40.1	6.3	100	0
14	wire+twine	0.90	hemp 323J	-	240	31.2	13.0	26	74
15	wire+twine	0.90	hemp 323 D	-	307	55.8	18.2	100	0
16	wire+attachm. steel wire	1.06	-	-	389	61.6	15.9	100	0
17	wire+twine	0.90	jute 1700x2 J	20	Measured value – big share of fallen vines				
18	wire+twine	0.90	jute 1700x2 D	2	Record mistake of central meas. station				
19	wire+twine	1.06	jute 1700x3 J	9	184	26.8	14.6	0	100
20	wire+twine	0.90	jute 1700x3 D	-	327	70.0	21.4	93	7
21	wire+twine	0.90	jute 2200x2 J	5	120	44.5	36.9	0	100
22	wire+twine	1.06	jute 2200x2 D	-	333	72.1	21.6	7	93
23	wire+twine	0.90	sisal 2000 J	27	Measured value – all vines fallen				
24	wire+twine	0.90	sisal 2000 D	13	Measured value – big share of fallen vines				
25	wire+twine	1.06	sisal 3300 J	14	Measured – big share of fallen vines				
26	wire+twine	0.90	sisal 3300 D	2	245	14.8	6.1	36	64
27	wire+twine	0.90	PP 11000 D	2	265	33.1	12.5	79	21
28	wire+twine	1.06	PP 17000 D	-	362	49.4	13.7	100	0

To break a new wire of 1.20, 1.30, and 1.40 mm in diameter it is necessary to produce a relatively big force which has 455 to 636 N on average, thus imposing unnecessary strain on the pulling equipment as well as to the supporting hop field trellis at pulling down. These wire diameters were used only for the purpose of checking the so-called wire-on-wire hopstring hanging, when the hop field supporting wire is directly winded by the hopstring wire at hanging. With this type of hanging there is no elastic element between the hopstring and supporting wire. Among hop growers there is an opinion saying that during the vegetation period of hop plants, hopstrings hung in this way tend to break due to the wind. The breaking force of twines reaches in most cases a higher value than with the

most frequently used wire of 1.06 mm in diameter. These are the values measured with new twines, though.

Another part of this research compares the force at break of new and used twines. There we prove its substantial decrease. The weather conditions and probably also application of plant protection chemicals cause substantial damage to the twine material.

Conclusion

The measurement results show that as an effective variant of hopstring hanging proved to be the combination of a black annealed wire 1.06 mm and a polypropylene twine of strength designation 12 500 in the form of a simple attachment. The given variant showed 100 % successful break in the place of a twine at pulling down. Even better results were shown by the variant of wire 1.06 mm and a jute twine of designation 2200x2 in the version of double attachment. In this case from the total amount of vines in 93 % the break in a twine occurred, and only in 7 % the break in the supporting wire occurred. 57 % twines break right in the place of the attachment to the hop field supporting wire. The other variants using a jute or sisal attachment are unsuitable due to fallen vines during the period of vegetation. The paper attachments will be subject to further testing. The opinion, saying that the hopstring hung by the method "wire on wire" results in hopstring fall, did not prove. Yet, here it is necessary to emphasise that for the purpose of the experiments, bigger wire diameters had been chosen. With the hopstrings hung by means of galvanized staples a problem occurred. At pulling down the vines the staple starts opening and then moves along the supporting wire. With the steel wire attachment some vines also moved along the supporting wire at the harvest. The sisal twine is not able to be incapable of resisting the weather conditions during the whole hop plant vegetation period.

Acknowledgement

This paper was supported by the Ministry of Agriculture of the Czech Republic, Project No. QI101B071.

References

1. Vent L. et al. Mechanizované linky ve chmelařství. (Mechanized lines at hop production) VÚCH Žatec, 1970, 141 s.
2. Vent L., Rybka A., Heřmánek P., Hozník I. Pevnost chmelovodičů a jejich úchytů při sklizni chmele (Strength of hop training wires and their attachments during hop harvest), Chmelařství 1, 2012, pp. 2-5. ISSN 0373-403X.
3. Rybka A., Heřmánek P., Hozník I., Mašek J., Vent L. Analysis of various implementations of hop strings during hop production. Plant, Soil and Environment, vol 9, 2011, pp. 441-446.
4. Heřmánek P., Rybka A., Hozník I., Mašek J., Vent L. Engineering problems during pulling-down of hop strings and their attachments. In: Engineering for Rural Development. Latvia University of Agriculture, Faculty of Engineering, Jelgava, 2011, pp. 26-31.
5. Vent L., Rybka A., Heřmánek P., Hozník I. Zhodnocení analýzy pevnosti chmelovodičů a jejich úchytů v tahu při sklizni chmele (Evaluation of strength analysis of hop training wires and hanging elements in tension during the harvest). Mechanizace zemědělství, vol 61, 2011 pp. 167-173.