

SOME EXPERIENCE IN ENERGY SAVING TRAINING WITHIN AGRICULTURAL ENGINEERING EDUCATION

Sergei Rakutko

North-West Research Institute of Agricultural Engineering and Electrification
of the Russian Academy of Agricultural Sciences, Russia
sergej1964@yandex.ru

Abstract. Training in energy saving is an important task in agricultural engineering education. The author offers a new kind of competence, which is mandatory for the agricultural engineers – the competence to choose the energy saving design solutions. The author believes that this competence should be formed during the classes in special disciplines, in the first place. The paper describes a new method of training in energy saving. The pedagogic basis of the method is the profession-oriented technology of training in energy saving. This technology allows to create the above competence with the special training environment – information system of training in energy saving. The system is designed to organize the teacher-student communication. The continuous replenishment of the system with professionally relevant subject-oriented content is provided. Scientific basis of the method is the applied theory of energy saving in energeo-technological processes. The theory describes the energy state of agricultural energy systems taking into account their hierarchy and patterns of interaction between biological objects and artificial habitats. The article describes the experiment conducted by the author in the Far East State Agrarian University, Blagoveshchensk, Russia, in 2006-2010. The experiment results demonstrated that application of the new training method in energy saving provided a higher average grade, that indicated the higher quality of education, expressed in the form of established competence in energy saving. The main conclusion of the study is that the training process of agricultural engineers should be based on the information system of training in energy saving.

Keywords: competence, training in energy saving, agro-engineering education, theory of energy saving, design solutions.

Introduction

The main objective of modern agro-engineering education is to train competitive experts. The concept of competitiveness becomes a scientific category in pedagogical science [1]. An essential prerequisite to competitiveness of an expert is his competence in energy saving area, which, according to the author of this paper, has to be built up, first of all, during the classes in special disciplines in compliance with the state educational standard for the particular study program.

The term “energy saving” means implementation of legal, institutional, scientific, industrial, technical and economic measures aimed at efficient use of energy resources. Accordingly, the training in energy saving (TES) should create the relevant competence of the trainees in the above areas within their vocational training.

The purpose of this paper is to describe the author’s training experience in energy saving within the academic activity of an agricultural university.

Theory

Recent years feature significant changes in the higher education paradigm. Competence-based approach finds the increasing recognition. The outcome of an educational establishment’s activity is currently considered to be not only the system of knowledge and skills, but also a set of created key competencies of trainees, which are effectively implemented in their professional activity [2].

The competence, believes A.V. Hutorsky, additionally includes the personal attitude of a student to the object under study [3].

The issue of professional competence has to be considered with due account of the prerequisites to achieve it [4].

The urgency of energy conservation and the strict requirements to modern agro-engineering education allow suggesting a special type of competence, which is mandatory for future agricultural engineers – their competence to choose the energy saving design solutions. The author identifies the following components in the structure of this competence:

1. Motivational component, which characterizes the awareness of importance and meaning of energy saving, a positive attitude towards energy saving;
2. Cognitive component, which is based on the knowledge of theoretical foundations of energy saving, acquisition of skills required for professional choosing of energy saving design solutions;
3. Activity component, which includes a set of skills to organize the designing activity and shows the ability of an engineer to create new systems and technologies with due account of energy saving requirements;
4. Reflexive component, which shows, how an engineer analyses and estimates his activity in terms of achieved results, and allows understanding and evaluating the solution degree of the set tasks [5].

The need to optimally design and carry out the training course aimed to build up the above competence means that we are speaking of an educational technology in energy saving.

An educational technology is directed on the guaranteed achievement of the didactic objectives and has to disclose the ways and conditions how to achieve these objectives [6].

V. P. Bepalko [7] expressed his vision of a pedagogical technology as a systematic and consistent realization in practice of the pre-designed educational/bringing-up process; he defined a pedagogical technology as a certain pedagogical system being introduced into practice.

American researcher Philip Coombs [8] takes a broad approach to an educational technology and includes in the concept everything that is involved in the training process and contributes to the educational system performance (different methods, materials, equipment, supply system, etc.).

Another approach to an educational technology considers the latter as a complex integrative process, which involves people, procedures, ideas, resources and organization, and is designed to analyse the problems, to make recommendations, to implement, evaluate and manage the solution of problems related to all educational aspects [9].

An educational technology is also known to be defined as a detailed presentation of all the modelling aspects of learning situations that would use any training methods and techniques, which are estimated as most appropriate to achieve the educational goals set for the trainees [10].

An educational technology includes both a teacher and a student (trainee) as actors [11]. G.K. Selevko classifies educational technologies by essential and instrumentally significant properties [12]. Classification of S.A. Smirnov lists educational technologies according to the used means and the level of implementation of the content of education [13]. A.I Chernilevsky identifies technologies of problem-based learning, concentrated learning, modular training, developmental teaching, graduated learning, contextual learning and education through play [14]; E.N. Shiyanov and I.B. Kotova identify technologies of transformation of knowledge, skills and abilities, problem-based learning, programmable, multi-level, adaptive and modular training [15].

Y.A. Saveliev groups existing technologies by the criteria of action orientation (personal development and career oriented, etc.); by the training objectives (formation of knowledge, development of skills, etc.); by the subject environment (humanitarian and socio-economic, natural science, technical and special disciplines); by applied technical means (audio-visual, informational, telecommunication, etc.) [16].

In summary, an educational technology is such a structuring of the educative process, which provides a certain system of actions and interactions of all the active elements of the process.

Subsequently, a profession-oriented technology of training in energy saving should be understood to mean a technology, which helps to build-up the competences of trainees to ensure their professional performance in the energy saving decision-making in the future professional activity of agricultural engineers.

The main items of profession-oriented technology of training in energy saving are:

- preliminary designing of TES process, with the possibility of its introduction into the pedagogical practice;
- definition of didactic objectives of TES with the later objective control of their achievement;
- structural and substantive integrity of TES process;

- development and selection of specific, interrelated, optimal methods, forms and means of TES process;
- feedback availability, allowing for timely correction of TES process.

It is suggested that special disciplines in agricultural engineering education study a common object – an artificial bio-energetic system as a set of power plants, technological processes and devices used in the agriculture branches to carry out required technological operations with the aim to produce and process the raw materials into intermediate and final products of consumption. Scientific basis of such an approach is the applied theory of energy saving in energeo-technological processes. The theory describes the energy state of artificial bio-energetic systems taking into account their hierarchy pattern and regularities of interaction between agricultural biological objects and artificial habitat. An artificial bio-energetic system has its own structure, the elements of which are studied during the classes in the corresponding special disciplines [17].

Materials and methods

A pedagogical experiment was conducted by the author at the Faculty of Electrification and Automation of Agriculture of the Far East State Agrarian University, Blagoveshchensk, Russia, in 2006-2010. The aim of research was to identify the possibility to create the competence to choose the energy saving design solutions in the course of professional training of agricultural engineers with the use of the profession-oriented technology of training in energy saving when studying certain disciplines of the chosen speciality.

The special training environment – information system of training in energy saving was used, the structure of which is shown in Fig. 1.

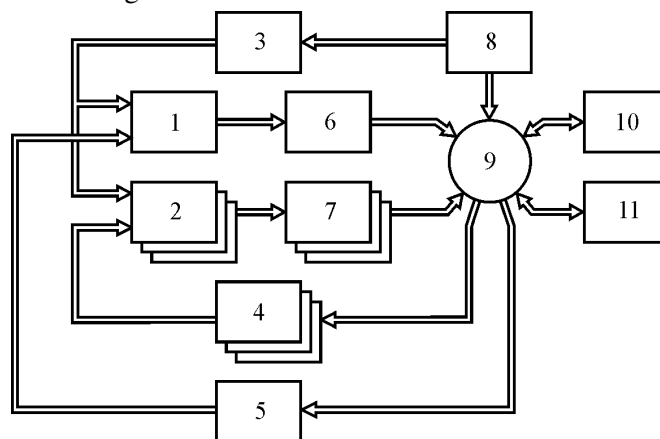

Fig. 1. The structure of information system of training in energy saving

The system operates on the basis of teaching aids, which are either hardware – computers and communication equipment, or software – programs for the control computer (not shown on the chart).

At first the teachers 3 filled the local knowledge bases in energy saving 1 and in subject areas 2 with the information from the global information space 8 (regulatory documents, educational, scientific and technical literature, etc.). The knowledge base in energy saving was designed to supply information on the theoretical basics of energy saving, common to all special disciplines. The knowledge base in subject areas was designed to provide standard training material in special disciplines. The data from the local knowledge base in energy saving at the beginning of TES were given to the trainees through the output unit of materials in the theoretical basics of energy saving 6.

In the study course of certain special disciplines the students received some samples from an array of signals of the local knowledge bases on the relevant subjects 2 through the corresponding output units 7. In the training process the students 9 produced the signals for the units of energy efficiency analysis 10 and optimization of energy intensity 11 using the signal arrays from the global information space 8. With the use of additional signal arrays from the global information space 8, the students 9 interacted with the unit of energy efficiency analysis 10 to register the optimal value of energy efficiency criterion.

After the training course on a certain special discipline had been completed, the shift in the level of the competence to choose the energy saving design solutions was registered for all students.

The development level of the competence components was assessed by anonymous questionnaire survey. The trainees were offered to choose the following descriptions of their command in separate components: «understand completely, can understand and use in practice» (5 points); «understand, can try to apply in practice» (4 points); «have a general understanding, find it difficult to apply in practice» (3 points); «can't imagine what it is and how to use it» (2 points).

The obtained points were summed up within i -th component. The results were shown as a percentage of maximum possible value; that it means a coefficient characterizing the level of development of individual competence component was derived:

$$U_i = \frac{\sum_{j=1}^n K_j}{\sum_{j=1}^n K_{j\max}} 100\%, \quad (1)$$

where K_j – the number of points gained on i -th component;

$K_{j\max}$ – maximum number of points that can be gained on i -th component.

After the study of each special discipline had been completed, the knowledge gained by the trainees was added to the local knowledge bases in the relevant subject area 2 through the corresponding memory unit for energy saving in the subject area 4.

The study courses of certain special disciplines were held until all the latter had been mastered according to the training program in the field of education. After that the knowledge gained by the trainees was added to the local knowledge bases in energy saving through the corresponding memory unit for energy saving in the field of education 5.

At the end of the training course in the field of education the training results were registered.

The experiment was held for five years in a subdivision of students of the same academic level consisting of four student groups: two groups were experimental and two groups were reference. The number of students in the groups varied by the year. All in all 287 students participated in the five-year experiment.

The education of experimental groups of students was structured with the use of the profession-oriented technology of training in energy saving. The education of the reference groups was based on a traditional technology, under which in each special discipline several extra lessons were given on the energy saving in this particular subject area. Education quality indicator was the average grade, which the members of the State Attestation Commission gave to the students for their graduate qualification thesis taking into account the diploma students' competences in energy saving [18].

Results and discussion

Changes in the competence to choose the energy saving design solutions of trainees in the special discipline "Light Engineering" is presented in Figure 2. A dotted line shows the level of competence components before the training in the discipline, a solid line – after the training in the discipline.

The integrated data show that the dynamics of the competence components is characterized by the growth and sufficient harmony. Thus, the motivational component increased from 48 % to 92 % (1.9 times), the cognitive component – from 33 % to 76 % (2.3 times), the activity component – from 30 % to 54 % (1.8 times), the reflexive component – from 34 % to 55 % (1.6 times).

Fig. 3. presents the graphs of behaviour of the average grade for the graduate qualification thesis during five successive years of the experiment for the groups of students trained with the use of the profession-oriented technology of training in energy saving and the groups trained with traditional methods.

The pedagogical experiment has demonstrated the following results:

1. Reduction in duration of training in energy saving – the reference group required additional special lessons in energy saving in contrast to the experimental group, and this extended the training course in the relevant subject area;
2. Achievement of the training process objective – application of the new TES technique provided a higher average grade, that indicated the higher quality of education, expressed in the form of established competence in energy saving;

Higher administration efficiency of the technological process of training has been achieved through the application of the information system of training in energy saving, which allows to develop algorithms, and to have software and hardware support.

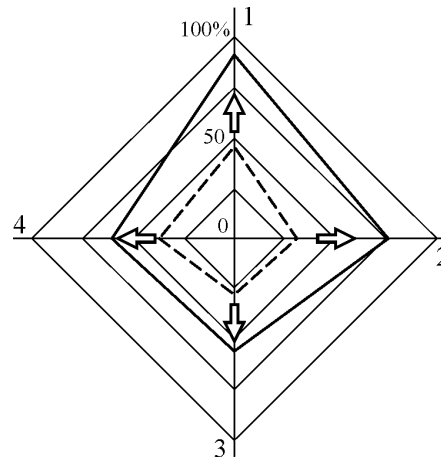

Fig. 2. **Summary diagram of dynamics of the competence components (%)**:
1 – motivational; 2 – cognitive; 3 – activity; 4 – reflective

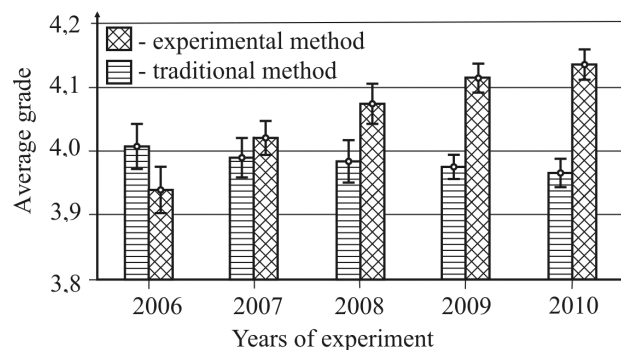

Fig. 3. **Behaviour of the average grade given by the State Attestation Commission**

In addition, the proposed TES provides a self-organizing flow of fragments of knowledge bases on special disciplines and energy saving, which continuously update the information system of training in energy saving.

The obtained results allow to acknowledge the sustainable pedagogical effect of application of the profession-oriented technology of training in energy saving.

Conclusions

1. It is suggested to consider the competence in the field of energy saving as a personal, integrative, creatable characteristic of qualification and willingness of students – future agricultural engineers to apply special design and engineering knowledge and skills; to search for and choose energy saving design solutions; to use the state-of-the-art technologies and designing tools; to apply the informed choice and optimization in case of multiple solutions; and to take into account the rapid technology changes.
2. The most important organizational and pedagogical condition for creation of the competence to choose the energy saving design solutions is application of the profession-oriented technology of training in energy saving.

3. The training process should be based on the information system of training in energy saving, which allows to establish the teacher-student communication and to guarantee the achievement of didactic objectives; this system provides for extensible continuous replenishment of current profession-oriented content.
4. In the educational process, when training in energy saving, it is advisable to use the provisions of the applied theory of energy saving in ergo-technological processes, which studies an artificial bioenergetic system in the framework of individual special disciplines.

References

1. Katane I. Competitiveness of Personality as a New Concept in Modern Education and Pedagogy. Proceedings of the 9th International Scientific Conference "Engineering for Rural Development", May, 27-28, 2010, Jelgava: LLU, pp. 324-334.
2. Ляпунова Т.Ю. Структурирование компетенций как фактор повышения эффективности оценки качества образовательного процесса (Structuring of competencies as an evaluation improvement factor of the training process quality) // Proceedings of the International Scientific and Practical Conference, 22 April, 2009, «Innovative Directions in Education», Part 3- Ekaterinburg: Urals State Polytechnic University, 2009.-pp.91-93. (In Russian)
3. Хуторской А.В. Ключевые компетенции как компонент личностно-ориентированной парадигмы образования (Key competences as a component of the personality-oriented paradigm of education) // Public Education. - 2003. - № 5. – pp. 58-64. (In Russian)
4. Гуружапов В.А. Проблема развития профессиональных компетенций будущих специалистов (The problem of professional competence development of future experts) // Psychological Science and Education.-2008.-№3.-pp.5-8. (In Russian)
5. Ракутько С.А. Принятие энергосберегающих проектных решений как обязательная компетентность выпускников технических вузов (The energy saving decision making as a binding competence of graduates of technical higher educational establishments) // Engineering Education.-2009.-№5.-pp.72-77. (In Russian)
6. Образцов П.И. Профессионально ориентированная технология обучения: особенности проектирования и конструирования (Professionally focused technology of training: specific features of design and construction) //Alma Mater. – 2003. – №10. – pp. 14-17. (In Russian)
7. Беспалько В.П. Слагаемые педагогической технологии (The components of a pedagogical technology).- Moscow: Pedagogica Publishers, 1989.-192 с. (In Russian)
8. Coombs Philip. The World Educational Crisis.- NY., 1970.- 130 p.
9. Educational Technology – its Creation, Development and Cross-Cultural Transfer. (R.M. Thomas and V.N. Kobayashi (eds.) - Oxford, 1987.-P.1.
10. Percival, F., Ellington, H. A Handbook of Educational Technology.- London, N.Y., 1984.-P.12.
11. Кларин М.В. Педагогическая технология в учебном процессе (Pedagogical technology in educational process).- Moscow, 1989.-С.36-41. (In Russian)
12. Селевко Г.К. Современные образовательные технологии: Учебное пособие (Modern educational technologies: textbook). -M.: Public Education Publishers, 1998.-256 p. (In Russian)
13. Смирнов С.И. Технологии в образовании (Technologies in education) // Higher Education in Russia.-1999.-№1.- pp.109-112. (In Russian)
14. Чернилевский Д.В. Дидактические технологии в высшей школе (Didactic technologies in the higher school).- Moscow, UNITI-DANA Publishers, 2002.- 437 p. (In Russian)
15. Шиянов Е.Н., Котова И.Б. Развитие личности в обучении (Development of personality in the training process).-Moscow, Academia Publishers,1999.-288 p. (In Russian)
16. Савельев А.Я. Технологии обучения и их роль в реформе высшего образования (Educational technologies and their role in the reform of higher education) // Higher Education in Russia.- 1994.-№2.-pp.29-37. (In Russian)
17. Ракутько С.А. Прикладная теория энергосбережения в эрготехнологических процессах АПК: структура и основные положения (Applied theory of energy saving in ergo-technological processes in Agro-Industrial Complex: structure and basic provisions) // Energy Saving and Water Treatment. –2009. -№ 4.- pp. 65-67. (In Russian)
18. Ракутько С.А. Обучение энергосбережению: компетентностный подход (Training in energy saving: competence approach). – Blagoveshchensk: Far-East Agricultural University Publishers, 2010. - 209 p. (In Russian).