

OSCILLATIONS OF PARTIALLY FILLED TANKER TRUCK AT ITS BRAKING

Alexandr Shimanovsky
Belarusian State University of Transport
tm.belsut@gmail.com

Abstract. A significant part of liquids in agricultural production is transported by road tanks. Moving with liquid cargo is a complex dynamic system and special attention should be paid to the relative displacement of cargo, which can lead to loss of stability and controllability of the car. The main purpose of the work is to analyze the influence of spring stiffness and wheel weight on partially filled tanker truck oscillations at braking. The mathematical modeling of the “road tank – transported liquid cargo” was performed. It was based on the scheme, which considered the transported liquid as a solid body that interacts with the tank through the viscoelastic connection with the nonlinear dependence of the elastic force on the cargo relative movement. Based on the numerical solution of the differential equations for the tank motion the influence of the cargo relative movement on the automobile stopping distance, as well as friction between the wheels and the road at the tank braking were analyzed. Calculations showed that for the tank without baffles there is an alternation of friction with and without sliding. This can cause losses of car controllability and overturning. The performed analysis confirms that there is a need of transverse baffle installation to ensure tank controllability at emergency braking. These partitions allow to damp liquid cargo oscillations quickly or to ensure the best possible liquid cargo energy dissipation.

Keywords: tanker truck, liquid cargo oscillations, braking, forces of friction, slipping.

Introduction

In agricultural production there is a need of constant liquid cargo transportation. At the places of tank filling reservoirs are filled by the maximal allowed level but after some technological operations are performed the filling level of the tanks decreases. For example, this fact takes place while dispensing liquid cargoes for consumers. At the same time, it is possible to increase the filling level of the tank reservoir after operations at several special stations. Therefore, due to agricultural operational needs the moving road tank is often partially filled with liquid. The risk of a dangerous situation increases during the transportation process of such road tank. This is due to the fact that the vehicle dynamic characteristics change because of the comparability of the empty tank weight with the liquid cargo weight and these characteristics are also different from a fully filled or an empty vehicle [1]. The maximal mechanical stresses appear in the fully filled tanks [2]. As for the case of partially filled tank movement the greatest practical interest is the study of the tank dynamic characteristics at transient movement modes, because of the increasing probability of an accident.

Traditionally, in the models of road tank motion, rocket and space apparatus, marine tankers and others vehicles and equipment liquid was modeled by equivalent mechanical models [3-5]. Parameters of such equivalent systems can be determined on the basis of the study of liquid small oscillations in the tank. Such oscillations can be approximately taken into account at calculation of vehicles by the use of an equivalent mechanical model consisting of a concentrated mass, associated with the vehicle body by linear elastic coupling means. However, this model does not consider oscillation damping caused by liquid cargo wave dispersion and viscosity. So, it can be only applied to the analysis of reservoirs with one or several separate compartments of regular geometric shape. The author of the work [6] notes that the dissipative forces must also be taken into account in the calculation schemes, but the investigators also offer to determine these forces experimentally for each case.

In the last few years there was carried out a number of studies based on the performed finite element modeling of liquid oscillations in a moving tank [7-10]. However, these investigations did not considered possible slipping between the vehicle wheels and the road. The computations including analysis of friction in the vehicle-road system can be implemented in the software package MSC.ADAMS [11], but in this case there can difficulties appear in determining the causes of different dynamic effects due to the big amount of the model parameters, which may be presented either in the form of graphs or tables.

The paper [12] demonstrates calculation results for the braking process of a road tank. These calculations are based on the analysis of a simplified model of a tank with liquid cargo, as a system with two degrees of freedom and unaccounted wheel weight. The results of the calculations allowed to

find that short-term periodic slipping of the tank wheels caused by cargo oscillations can be observed during tank emergency braking. This can cause loss of the car control and appearing of a dangerous situation. The aim of the present work is to determine the features of the friction forces changes between the wheels and the road for the case of tank braking using on a more complex model and taking into account the tank body oscillations on the springs and inertia of wheels.

Tank truck mathematical model

For the analysis of tank braking trucks at its motion along the horizontal surface the analyzed system was considered as a system including the tank body, wheels of the front and rear axles, the transported liquid. The moving part of liquid cargo can be determined from the formulas given in [6]. The calculation scheme is shown in Fig. 1.

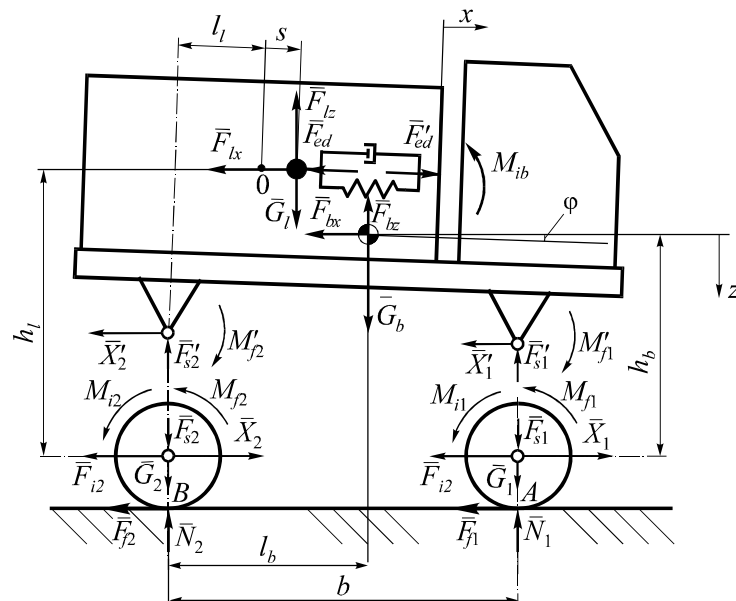

Fig. 1. Scheme of the tank with equivalent liquid cargo

In the scheme and further text the following symbols are used:

m_b, m_l, m_1, m_2 – weight of the tank body, front and rear axles respectively, kg;

I_b, I_1, I_2 – moments of inertia of the tank body, the front and rear axle respectively, kg·m²;

x, z – coordinates of the tank body center of mass at its motion relative to the earth, m;

s – coordinate of the liquid cargo center of mass in the relative motion, m; the beginning of its counting corresponds to the position of cargo equilibrium inside the tank, so it corresponds to the deformation of the elastic connection between the cargo and body;

$\varphi, \varphi_1, \varphi_2$ – rotation angles of the tank body and wheels of the front and rear axle respectively, rad;

b – car base, m;

l_b, l_l – distance from the rear axle to the tank body and cargo centers of gravity in the equilibrium position respectively, m;

h_b, h_l – vertical coordinates of the tank and cargo centers of gravity respectively, m;

G_b, G_1, G_2 – gravity forces of the tank body, front and rear axles respectively, N;

M_{f1}, M_{f2} – moments generated by the front and rear axle brakes, N·m;

F_{f1}, F_{f2} – friction forces between the wheels of the front and back axles and the road, N;

N_1, N_2 – normal reaction of the road for the front and back axles, N;

X_1, X_2 – horizontal interaction forces between the axles and the vehicle body, N;

F_{s1}, F_{s2} – forces in the springs of front and rear axles, N;

F_{ed} – resultant force of the liquid-tank body interaction, N;

$F_{bx}, F_{bz}, F_{lx}, F_{lz}$ – projections of body and cargo forces of inertia on the axis x and z , N;

F_{i1}, F_{i2} – front and rear axle forces of inertia, N;

M_{ib}, M_{i1}, M_{i2} – moments of inertia forces of the tank body, front and rear axles respectively, N·m.

The forces in the springs are connected with the tank body movement by the dependencies:

$$F_{s1} = c_1(z_s + (b - l_b)\varphi); \quad F_{s2} = c_2(z_s - l_b\varphi). \quad (1)$$

To account for the viscous resistance forces of liquid cargo its mass is connected to the reservoir by the viscoelastic element. In this case, the interaction force between the cargo and wall F_{ed} can be represented as the sum of two terms: the elastic and dissipative component of the interaction force

$$F_{ed} = cs + \alpha\dot{s}. \quad (2)$$

where c – coefficient determined by the shape of the tank and the filling level; it is involved to consider the effects of liquid movement on the tank body cell and it can be determined as

$$c = c_0 \text{ if } s \leq s_0, \quad c = c_0 e^{\frac{s-s_0}{3(s_{\max}-s)}} \text{ if } s > s_0, \quad (3)$$

c_0 – value of the coefficient c for the case of liquid small oscillations [6], N·m⁻¹;

s_0 – coordinate s , when liquid reaches the cell, m;

s_{\max} – coordinate s , for the case when all liquid cargo is located near one of the sides of the tank body and its free surface is vertical, m;

α – coefficient allowing to take into consideration liquid oscillation damping in the road reservoir, kg·s⁻¹.

The dot over the variable here and further denotes the derivative calculated by time.

Formula (3) is obtained by the approximation of the calculation results of liquid cargo oscillations in road tanks [13] and showed good agreement with the experiment [14].

Equations for the inertia forces can be in the following view:

$$F_{bx} = m_b\ddot{x}, \quad F_{bz} = m_b\ddot{z}, \quad F_{lx} = m_l(\ddot{x} + \ddot{s}), \quad F_{lz} = m_l(\ddot{z} - (l_b - l_l - s)\ddot{\varphi}), \quad F_{i1} = m_1\ddot{x}, \quad F_{i2} = m_2\ddot{x}. \quad (4)$$

Moments of inertia forces:

$$M_{ib} = I_b\ddot{\varphi}, \quad M_{i1} = I_1\ddot{\varphi}_1, \quad M_{i2} = I_2\ddot{\varphi}_2. \quad (5)$$

The angle φ is considered to be very small, so $\sin \varphi = \varphi$, $\cos \varphi = 1$. Then, in accordance with the D'Alembert principle the movement of the tank and relatively moving liquid cargo with taking into account relations (4) and (5) is described by the following equations:

$$\begin{aligned} F_{ed} - m_b\ddot{x} - X_1 - X_2 &= 0; \\ m_b\ddot{z} + m_l(\ddot{z} - (l_b - l_l - s)\ddot{\varphi}) + F_{s1} + F_{s2} - G_b - G_l &= 0; \\ M_{f1} + M_{f2} + X_1 b \varphi - F_{s1} b + G_b l_b - F_{bx} h_b - F_{bz} l_b + G_l(l_l + s) - F_{lz}(l_l + s) - F_{lx} h_l - I_b \ddot{\varphi} &= 0; \\ m_l(\ddot{s} + \ddot{x}) + F_{ed} &= 0. \end{aligned} \quad (6)$$

Equations for motion of the front and rear axes

$$\begin{aligned} m_1\ddot{x} - X_1 + F_{f1} &= 0; & m_2\ddot{x} - X_2 + F_{f2} &= 0; \\ N_1 - F_{s1} - G_1 &= 0; & N_2 - F_{s2} - G_2 &= 0; \\ I_1\ddot{\varphi}_1 + M_{f1} - F_{f1}r &= 0; & I_2\ddot{\varphi}_2 + M_{f2} - F_{f2}r &= 0, \end{aligned} \quad (7)$$

where r – tire radius.

At road tank braking there is possible a situation of wheel rotation along the road with and without slipping. Therefore, it should be noted that in general case the static friction force value for the location between the tire and the road may not exceed the production of the friction coefficient and road normal reaction

$$F_{f1} \leq fN_1, \quad F_{f2} \leq fN_2. \quad (8)$$

Likewise, when the disk brakes operate, the maximal torques $M_{1\max}$ and $M_{2\max}$ can be reached only when there is slipping of linings along the brake discs. These torques have the pointed values according to the technical characteristics of brakes on the front and rear wheels of the car. At the skidded wheel motion there can be a situation, when the braking torque is less than the maximal value, so the following conditions must be satisfied

$$M_{f1} \leq M_{1\max}, \quad M_{f2} \leq M_{2\max}. \quad (9)$$

Thus, calculation of the road tanker braking is based on the solution of differential equations (6) and (7) considering the relations (1)-(4), (8) and (9).

Further calculations performed in the MathCAD environment showed that the presence of inequalities (8) and (9) leads to inadequate results of the generalized acceleration calculation or the divergence of nonlinear equation system solution on separate time intervals using the built-in function "Find". It turned out that this situation is caused by the nonlinearity appearing due to the need to adjust the friction force values for two cases. The first case corresponds to the motion with slipping, the second case – without slipping. The problem was solved by using the built-in function "Minerr". It differs from "Find" in that, if the chosen algorithm fails to converge, whatever answer found on the last allowable iteration is returned.

Results and discussion

On the basis of the presented dependences the calculations were performed of the based on the MAZ-437041 chassis road tank. Model parameters were taken in accordance with the paper [12]. Maximal braking torques in the chassis brake pads are taken $M_{1\max} = 7000 \text{ N}\cdot\text{m}$ for the front axis and $M_{2\max} = 2800 \text{ N}\cdot\text{m}$ for the rear axis.

The calculation results show that for the coefficient α equal to 1000-20000 $\text{kg}\cdot\text{s}^{-1}$ the changes in the braking distance do not exceed 1 %. This result is fully consistent with the results of calculations with zero wheel mass [12].

Taking into account the spring deformation and mass of the wheels did not lead to a significant change in the parameters of the liquid cargo oscillations. Coefficient α has the greatest influence on the movement and velocity of the liquid cargo center of mass (Fig. 2). If the value of this coefficient is more than 20000 $\text{kg}\cdot\text{s}^{-1}$, the liquid cargo motion becomes aperiodic. These values of the named coefficient can be achieved by internal perforated baffle install [15].

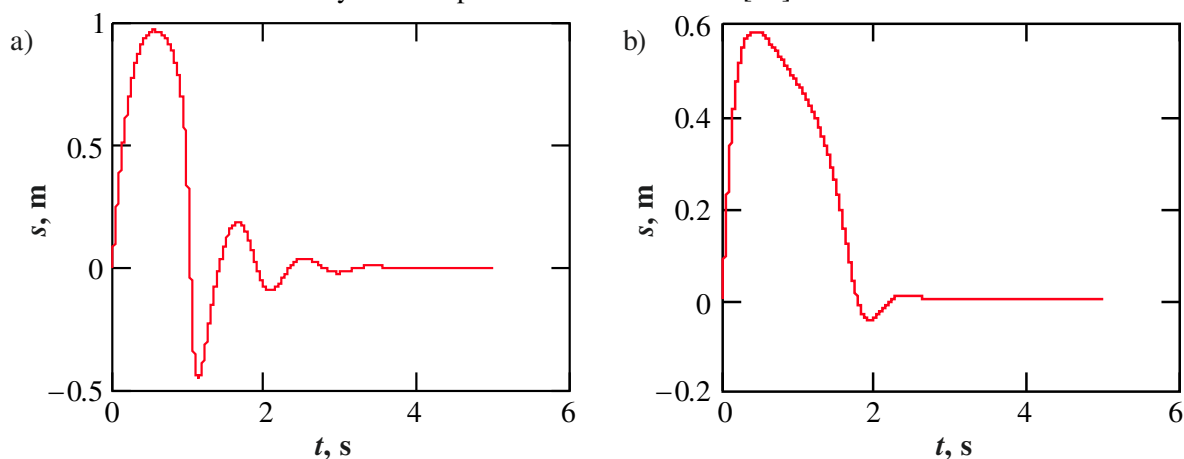

Fig. 2. Relative velocity of liquid cargo centre of mass for:

a – $\alpha = 10000 \text{ kg}\cdot\text{s}^{-1}$; b – $\alpha = 20000 \text{ kg}\cdot\text{s}^{-1}$

Calculations performed taking into account the mass of the wheels and spring deformations confirmed the previously obtained result for the simplified model [12]. At low values of the coefficient α (tank without baffles) there is an alternation of tank movement modes with and without slipping. Consideration of additional factors leads to a significant change in the dependence of the friction force of the front wheel on time and it appears only when the wheels move with slipping (Fig. 3). For the rear wheels considering of their mass allows to specify the nature of the dependence of the friction

forces on time because the calculations for the simplified model demonstrated a constant value of these forces under the influence of the wide range of the factor α (Fig. 4).

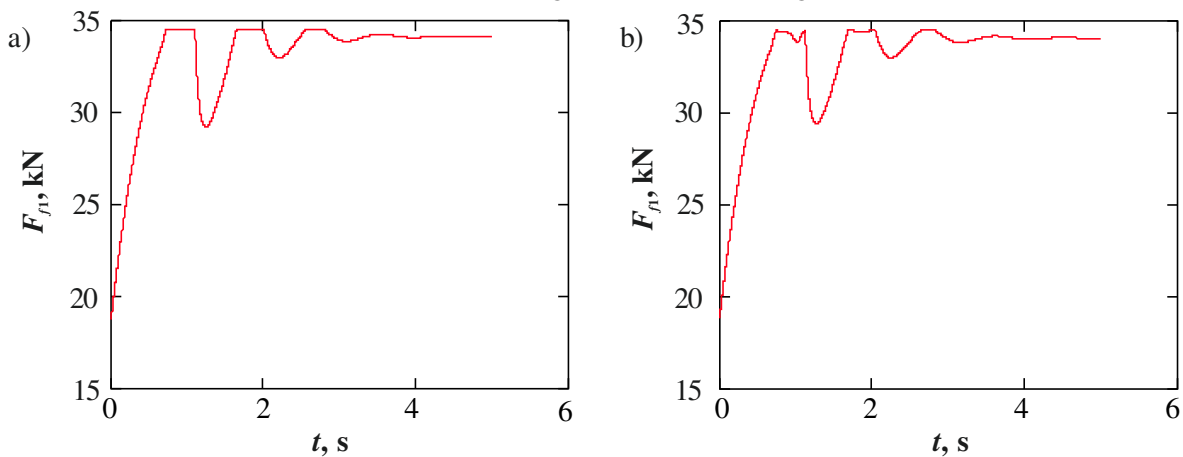

Fig. 3. Friction forces for the front wheels at $\alpha = 5000 \text{ kg}\cdot\text{s}^{-1}$: a – calculations without considering the wheel mass; b – calculations with taking into account the wheel mass

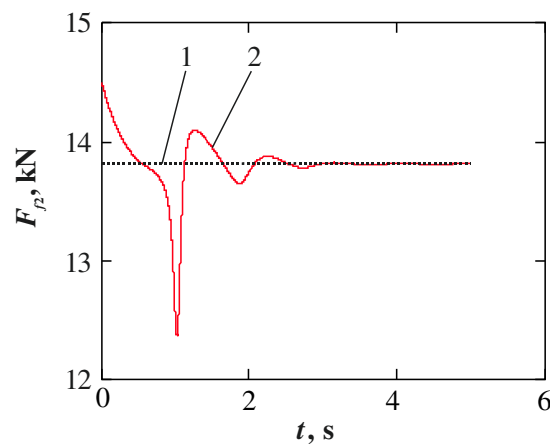

Fig. 4. Friction forces for the rear wheels at $\alpha = 5000 \text{ kg}\cdot\text{s}^{-1}$: 1 – calculations without considering the wheel mass; 2 – calculations with taking into account the wheel mass

The performed analysis demonstrated that the inclusion of the car spring deformation insignificantly affects the value of the friction force changes.

The changes in friction force values are connected with the modes of the wheel movement with and without slipping and can cause disturbances of the car controllability and its overturning. Furthermore, due to the friction hopping pushes the driver working conditions become worse. An increase in the coefficient α (corresponds to the tank with internal baffles) leads to the smooth changes in the frictional forces.

Thus, the performed analysis confirms that there is a need of transverse baffle installation to ensure the tank controllability at emergency braking. These partitions allow to damp liquid cargo oscillations quickly or to ensure the best possible liquid cargo energy dissipation.

For the cases, when it is impossible to install perforated baffles in the existing road tank constructions, it is recommended for drivers to use partial (smooth) braking to reduce the oscillation amplitudes of liquid cargo in the partially filled reservoir. This will allow to avoid the motion of wheels with slipping.

Conclusions

1. The performed analysis showed that complication of the model describing oscillations of a tank partially filled with liquid does not lead to significant changes in the results of the motion kinematic parameters and forces in the road-wheel contacts.

2. It was approved that at movement of the tank without partitions the relative displacement of liquid cargo leads to alternation of friction modes with and without slipping, which leads to a decrease of drivability and controllability of the road tank.
3. Installation of the partitions damping liquid cargo oscillations helps smooth the changes of the friction forces and it allows to reach a significant improvement of the braking conditions.

References

1. Высоцкий М.С., Плескачевский Ю.М., Шимановский А.О. Динамика автомобильных и железнодорожных цистерн (Dynamics of automobile and railway tanks). Minsk: Belautotractorostroenie, 2006. 320 p. (In Russian).
2. Lengvarsky P., Pástor M., Bocko J. Static Structural Analysis of Water Tank. American Journal of Mechanical Engineering, vol. 3, 2015, pp. 230-234.
3. Dai L., Xu L., Setiawan B. A new non-linear approach to analyzing the dynamic behavior of tank vehicles subjected to liquid sloshing. Proceedings of the Institution of Mechanical Engineers, Part K: Journal of Multi-body Dynamics, vol. 219, 2005, pp. 75-86.
4. Deng X., Tait M. J. Equivalent mechanical models of tuned liquid dampers with different tank geometries. Canadian Journal of Civil Engineering, vol. 35, 2008, pp. 483-495.
5. Ranganathan R., Yang Y. S. Impact of liquid shift on the braking characteristics of partially filled tank vehicles. Vehicle system dynamics, vol. 26, 1996, pp. 223-240.
6. Dodge F.T. The new "Dynamic behavior of liquids in moving containers". San Antonio: Southwest Research Institute, 2000. 195 p.
7. Cheli F., D'Alessandro V., Premoli A., Sabbioni E. Simulation of Sloshing in Tank Tracks. International Journal of Heavy Vehicle Systems, vol. 20, 2013, pp. 11-18.
8. Liu K., Kang N. Simulation of liquid slosh in braking process of tank truck. Journal of Beijing University of Aeronautics and Astronautics, vol. 35, 2009, pp. 799-803.
9. Yan G., Rakheja S. Straight-line braking dynamic analysis of a partly filled baffled and unbaffled tank truck. Proceedings of the Institution of Mechanical Engineers, Part D: Journal of Automobile Engineering, vol. 223, 2009, pp. 11-26.
10. Shimanovsky A., Kuzniatsova M., Sapietová A. Modeling of Newtonian and Non-Newtonian liquid sloshing in road tanks while braking. Applied Mechanics and Materials, vol. 611, 2014, pp. 137-144.
11. Sapietova A., Dekys V. Use of MSC.ADAMS software product in modelling vibration sources. Communications – Scientific letters of the University of Zilina, vol.18, No 1A, 2016, pp. 101-107.
12. Кузнецова М.Г. Анализ влияния перемещения жидкого груза в резервуарах цистерн на кинематические и динамические параметры автомобиля при торможении (Analysis of liquid cargo movement in road tanks reservoirs influence on the automobile kinematic and dynamic parameters at its braking). Topical questions of machine sciences: Актуальные вопросы машиноведения, 2014, No 3, pp. 201-204. (In Russian).
13. Шимановский А.О. Модифицированная дискретно-массовая модель цистерны с жидкостью (Modified discrete-mass model of tank with liquid). Mechanics, scientific researches and methodical development: Механика, научные исследования и учебно-методические разработки, 2011, vol. 5, pp. 163-165. (In Russian).
14. Gridnev S.Yu., Budkovej A.N. Modelling of fluctuations of beam systems at the transitional modes of the movement of vehicles carrying liquids. Scientific Herald of the Voronezh State University of Architecture and Civil Engineering, Construction and Architecture, 2015, No 2(26), pp. 48-61.
15. Kuzniatsova M., Shimanovsky A. Definition of rational form of lateral perforated baffle for road tanks. Procedia Engineering, vol. 134, 2016, pp. 72-79.